

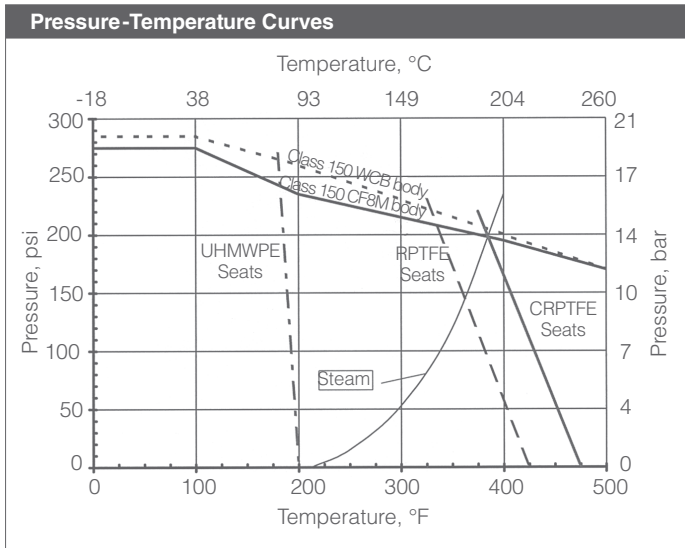

Features

- Investment cast 2-piece body construction
- ISO 5211 actuator mounting pad
- Blow-out proof stem
- Reinforced PTFE seats
- Adjustable, live loaded PTFE packing w/O-ring secondary seal
- API 598 inspection and testing
- PED 97/23/EC; ISO 9001
- Locking lever operator
- Ammonia service available upon request



Technical Specifications: Please refer to bottom page 3

2000F-xxx-CS-F1 Series Full Port Valve

2000F-xxx-S6-F1 Series Full Port Valve

Quick Spec	
Product Scope	
Size Range	1/2" – 6", Full Port
Body Type	2-pc Split Entry
Pressure Rating / Ends	ASME Class 150, Flanged Ends
Temperature Range / WSP	-20°F to 400°F / 150 psi Steam -29°C to 204°C / 10,3 bar steam
Body	Stainless or Carbon Steel
Ball & Stem	Stainless Steel, Anti Static Design
Ball Seats	RPTFE
Stem Packing	Adjustable, Live Loaded PTFE
Stem Seals	Viton O-Ring
Body Seal / Thrust Washer	RPTFE / RPTFE (50% SST)
Operator / Mounting Pad	Manual Locking Lever / ISO 5211
Design Standards	
Design	ASME B16.34
Face to Face	ASME B16.10
Flange Dimensions	ASME B16.5
Testing Standards	
Pressure Testing	API 598
Approvals	
PED 97/23/EC; ISO 9001	

Materials of Construction		
Part	Stainless Steel	Carbon Steel
Body	ASTM A351 CF8M	ASTM A216 WCB
End Cap	ASTM A351 CF8M	ASTM A216 WCB
Ball	ASTM A351 CF8M	
Stem	AISI 316	
Seat Ring	RPTFE	
Seal, Body	RPTFE	
Bolt, Body	ASTM A193 B8 Class I (1/2"-4") / AISI 304 (6")	
Antistatic Pin (1/2"-4")	AISI 316	
Bearing Washer	50% SS / 50% PTFE	
Thrust Washer	PTFE	
Packing	PTFE	
O-Ring, Stem (1/2"-4")	Viton	
Packing Follower (1/2"-4")	AISI 304	
Gland (6")	ASTM A351 CF8M	
Belleville Washer (1/2"-4")	AISI 304	
Bolt, Gland (6")	AISI 304	
Stop Plate (1-1/2"-6")	AISI 304	
Lock Washer (Saddle), Packing Nut (1/2"-1")	AISI 304	
Nut, Packing (1/2"-4")	AISI 304	
Retaining Ring (6")	AISI 304	
Adaptor, Handle (1-1/2"-6")	AISI 304 (1-1/2"-4") / Cast Iron (6")	
Handle (1/2"-1")	AISI 304	
Handle (1-1/2"-6")	Steel, Plated (2"-4") / Steel (6")	
Lock Washer, Handle (1/2"-1")	AISI 304	
Nut, Handle (1/2"-1")	AISI 304	
Bolt, Handle (1-1/2"-4")	AISI 304 (1-1/2"-4") / Steel (6")	
Cover, Handle (1/2"-4")	Vinyl	
Bolt, Stop (1/2"-4")	AISI 304	

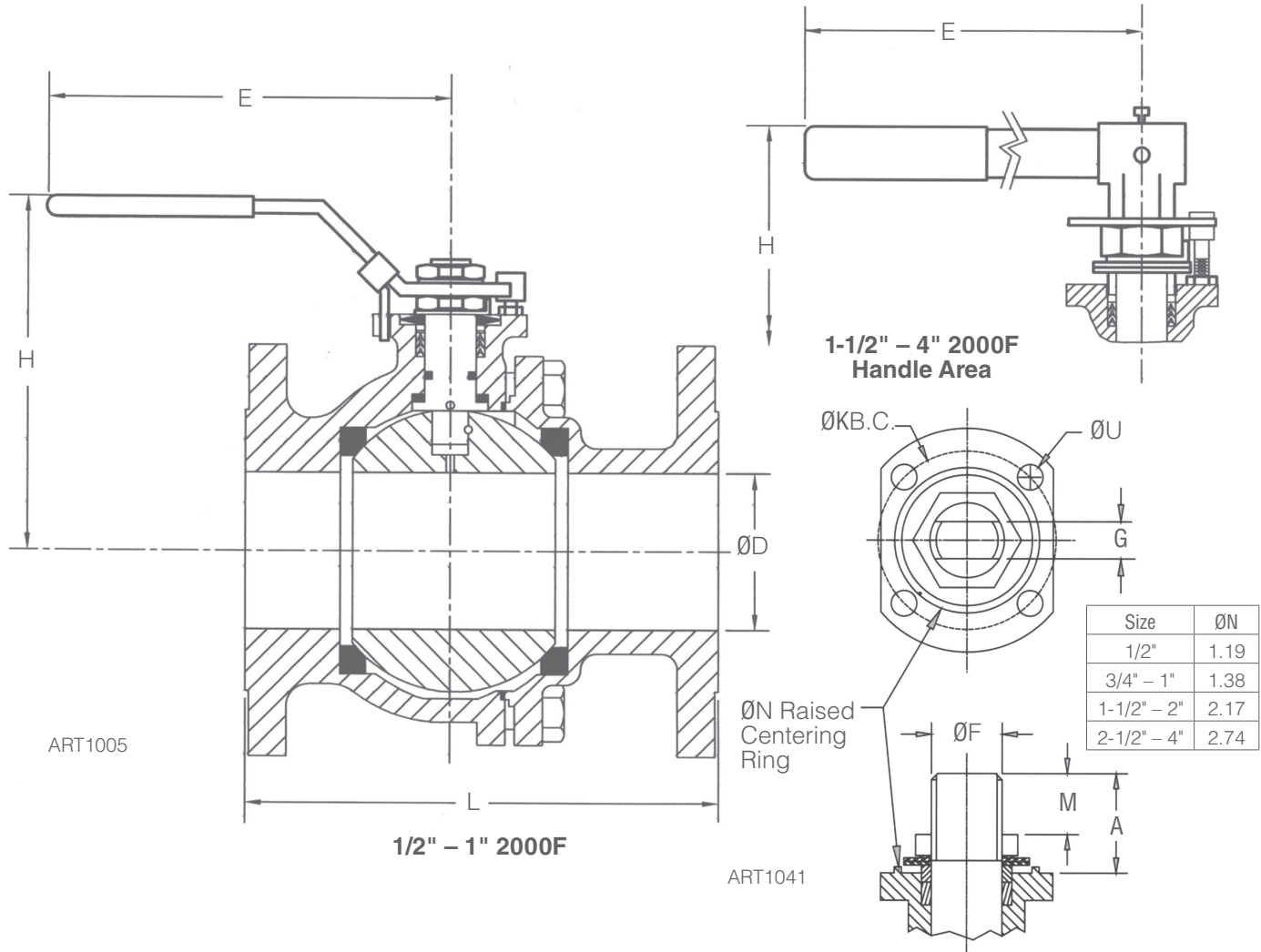

Dimensions, Inches													
Valve Size	2000F - 150 Series												Weight, lbs
Inches	ØD	L	H	E	ISO 5211	ØU	ØK	G	ØF	ØN	A	M	
1/2"	0.59	4.25	3.5	5.9	F04	M5	1.65	0.248	0.374	1.19	0.78	0.50	8.8
3/4"	0.79	4.63	3.9	5.9	F04	M5	1.65	0.248	0.374	1.19	0.71	0.41	9.9
1"	0.98	5.00	4.3	7.1	F05	M6	1.97	0.315	0.441	1.38	0.88	0.50	11.0
1-1/2"	1.57	6.50	5.0	7.4	F07	M8	2.76	0.374	0.626	2.17	1.14	0.70	17.6
2"	1.97	7.00	6.0	11.0	F07	M8	2.76	0.374	0.626	2.17	1.14	0.75	24.3
2-1/2"	2.56	7.50	7.0	15.0	F07	M8	2.76	0.669	0.870	2.17	1.67	0.85	37.5
3"	2.99	8.00	7.5	15.0	F10	M10	4.02	0.669	1.114	2.74	1.85	1.15	50.7
4"	3.82	9.00	9.0	15.0	F10	M10	4.02	0.669	1.114	2.74	1.89	1.20	68.3

Dimensions, mm													
Valve Size	2000F - 150 Series												Weight, kgs
NPS	ØD	L	H	E	ISO 5211	ØU	K	G	ØF	ØN	A	M	
DN15	15,0	108	89	150	F04	M5	42,0	6,3	9,5	30,2	19,8	12,7	4,0
DN20	20,0	117,6	99	150	F04	M5	42,0	6,3	9,5	30,2	18,1	10,4	4,5
DN25	25,0	127	109	180	F05	M6	50,0	8,0	11,2	35,1	22,4	12,7	5,0
DN40	40,0	165,1	127	188	F07	M8	70,0	9,5	15,9	55,1	29,0	17,8	8,0
DN50	50,0	177,8	152	279	F07	M8	70,0	9,5	15,9	55,1	29,0	19,1	11,0
DN65	65,0	190,5	178	381	F07	M8	70,0	17,0	22,1	55,1	42,4	21,6	17,0
DN80	76,0	203,2	191	381	F10	M10	102,0	17,0	28,3	69,6	47,0	29,2	23,0
DN100	97,0	228,1	229	381	F10	M10	102,0	17,0	28,3	69,6	48,0	30,5	31,0

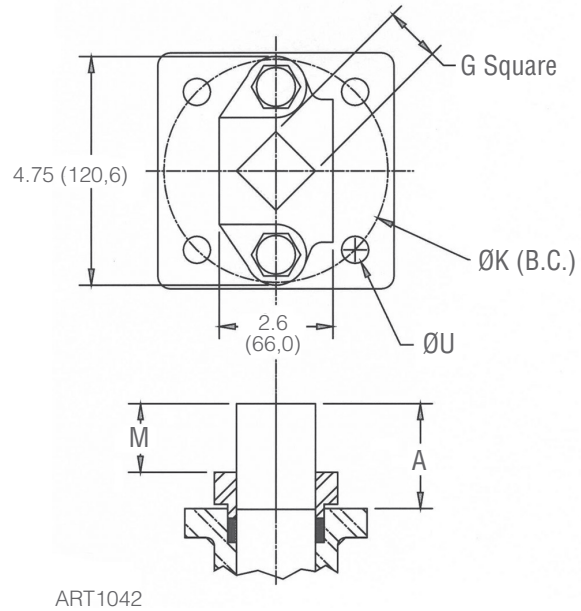
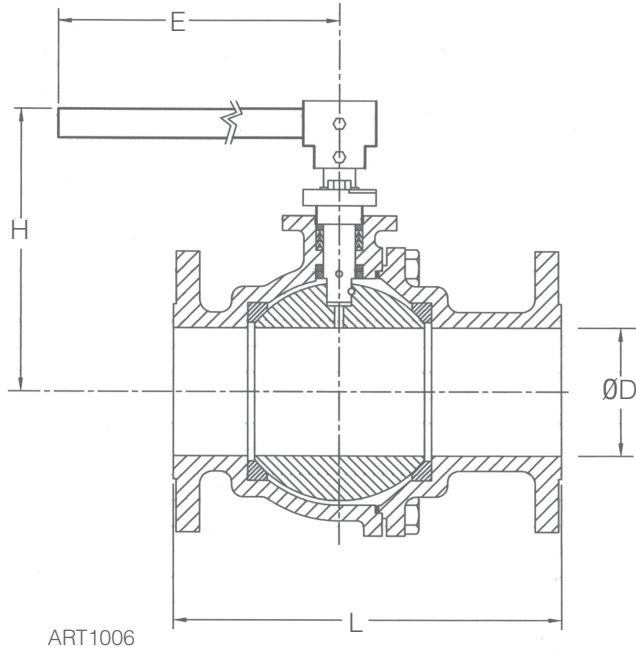

Dimensions, Inches											
Valve Size	2000F - 150										Weight, lbs
Inches	ØD	L	H	E	ISO 5211	ØU	ØK	G	A	M	
6"	5.8	15.50	11.5	26.5	F12	M12	4.92	0.984	3.03	2.19	125

Dimensions, mm											
Valve Size	2000F - 150										Weight, kgs
NPS	ØD	L	H	E	ISO 5211	ØU	K	G	A	M	
DN150	148	394	292	673	F12	M12	125	25,0	77,0	55,6	57

Technical Specifications		
Valve Size Inches	Operating Torque, in-lb @ 285 psig	Flow Coefficient, Cv
1/2"	88	29
3/4"	106	56
1"	110	90
1-1/2"	220	256
2"	380	424
2-1/2"	585	757
3"	900	1150
4"	1600	2000
6"	3500	5000

Technical Specifications, metric		
Valve Size NPS	Operating Torque, N-m @ 19,6 bar	Flow Coefficient, Kv
DN15	10	25
DN20	12	48
DN25	12	77
DN40	25	220
DN50	43	364
DN65	66	651
DN80	102	990
DN100	181	1720
DN150	395	4300

Model	Size	Body Mat'l	End Connections	1	2	3	4	5	6	7	8	9	10	11	12

Model Number	
2000F	2 Piece Ball Valve

Size	
050	1/2"
075	3/4"
100	1"
150	1-1/2"
200	2"
250	2-1/2"
300	3"
400	4"
600	6"

Body Material	
CS	Carbon Steel
S6	Stainless Steel

End Connections	
F1	Class 150 FE

Packing/Seat	
A	PTFE/PTFE
B	PTFE/RPTFE (Standard)
C	PTFE/C-RPTFE
G	Grafoil/C-RPTFE
J	UHMW-PE/UHMW-PE

Ends	
F	Class 150 FE

3&4		Operation	
HL	Lever		
NN	None		
P1	UT-0A-DA STD	S6	UT-3.5-SR STD
P2	UT-0-DA STD	S7	UT-4-SR STD
P3	UT-1-DA STD	SF	UT-4.5-SR STD
P4	UT-2-DA STD	S8	UT-5-SR STD
P5	UT-2.5-DA STD	S9	UT-6-SR STD
P6	UT-3-DA STD	M1	ER-1-2.5-4 110 VAC
P7	UT-3.5-DA STD	M2	ER-2-5-4 110 VAC
P8	UT-4-DA STD	M3	ER-3-5-4 110 VAC
S1	UT-0-SR STD	M8	ER-4-10-4 110 VAC
S2	UT-1-SR STD	M4	ER-6-15-4 110 VAC
S3	UT-2-SR STD	M5	ER-10-15-4 110 VAC
S4	UT-2.5-SR STD	M9	ER-15-30-4 110 VAC
S5	UT-3-SR-STD	MA	ER-20-12-4 110 VAC
ZZ	Non-Standard		

5&6		Actuator Pressure	
60	60 psi		
80	80 psi		
NN	N/A (no pneumatic actuator)		
ZZ	Non-Standard		

7&8		Solenoid Feature		Act. Type
00	None			
3A	3W 8551-120VAC N4 UT-0/5			SR
3C	3W EF8551-120VAc N7 UT-0/5			SR
3J	3W 8317G35-120VAC N4 UT-0/2.5			SR
3M	3W 8321G1-120VAC N4 UT-3/5			SR
3Q	3W EF8317G35-120VAC N7 UT-0/2.5			SR
3R	3W EF8321G1-120VAC N7 UT-3/5			SR
4A	4W 8551-120VAC N4 UT-0A			DA
4B	4W 8551-120VAC N4 UT-0/5			DA
4D	4W EF8551-120VAC N7 UT-0A			DA
4E	4W EF8551-120VAC N7 UT0/5			DA
ZZ	Non-Standard			

9&10		Limit Swtich	
00	None		
AA	LS FMYB-5120-N4 to UT-0/3		
AB	LS FMYB-5120-N4 to UT-3.5/7		
AC	LS AMYB-5120-N7 to UT-0/3		
AD	LS AMYB-5120-N7 to UT-3.5/7		
0Z	Non-Standard		

11&12		Fail Position	
NN	Fail Position N/A (No "SR" Actuator)		
01	Fail Closed		
02	Fail Open		

Marwin Valve

A Division of Richards Industrials, 3170 Wasson Road,
Cincinnati, OH 45209

toll free. 800.543.7311, local. 513.533.5600, fax.

513.871.0105

www.marwinvalve.com