



# EPR Series

High Precision Electronic Pressure and Vacuum Controllers  
Accurate to 0.25% of full scale

# How It Works

Pressure is controlled by the use of two solenoid valves. One valve functions as inlet control and acts to allow supply media into the system to increase the controlled pressure. The other solenoid valve acts as the exhaust and will decrease the controlled pressure by venting the system to atmosphere. Both solenoid valves operate proportionally to the current supplied by the EPR's electronic control circuit.

The regulated pressure output is measured by a solid state pressure transducer internal to the EPR. This pressure transducer provides a feedback signal to the EPR's electronic control circuit. The control circuit compares the internal sensor feedback signal to the command signal input. Any difference between the two signals causes the appropriate solenoid valve to open, allowing flow in or out of the system. Accurate pressure is maintained by controlling these two valves. See Fig. 1.

## PRECISE CONTROL FROM VACUUM UP TO 3000 PSI

The Equilibar EPR Series is a precision electronically controlled pressure and/or vacuum regulator. The EPR controls pressure or vacuum accurately and with high resolution within a closed volume or in a system with low flow rates. The dual valve technology controls pressure with minimal loss of expensive gases.

The EPR Series may be controlled with an analog or a digital command signal, or it can be quickly commanded using the convenient keypad interface.

**NOTE:** Equilibar offers intrinsically safe/ATEX-rated instruments, but this brochure is not for those instruments. ATEX-rated instruments have specific requirements for power supply and IP rated enclosures. For information, please [contact Equilibar](#).

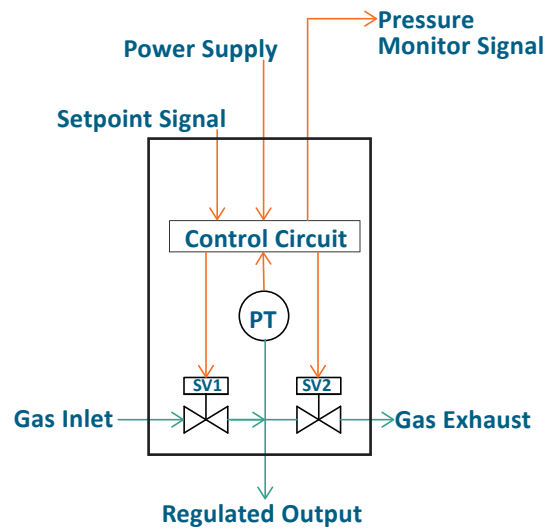

Fig. 1 EPR Diagram

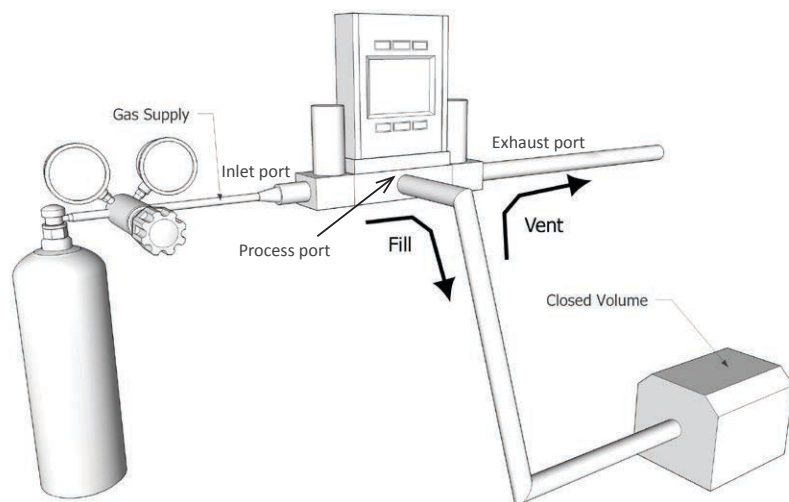
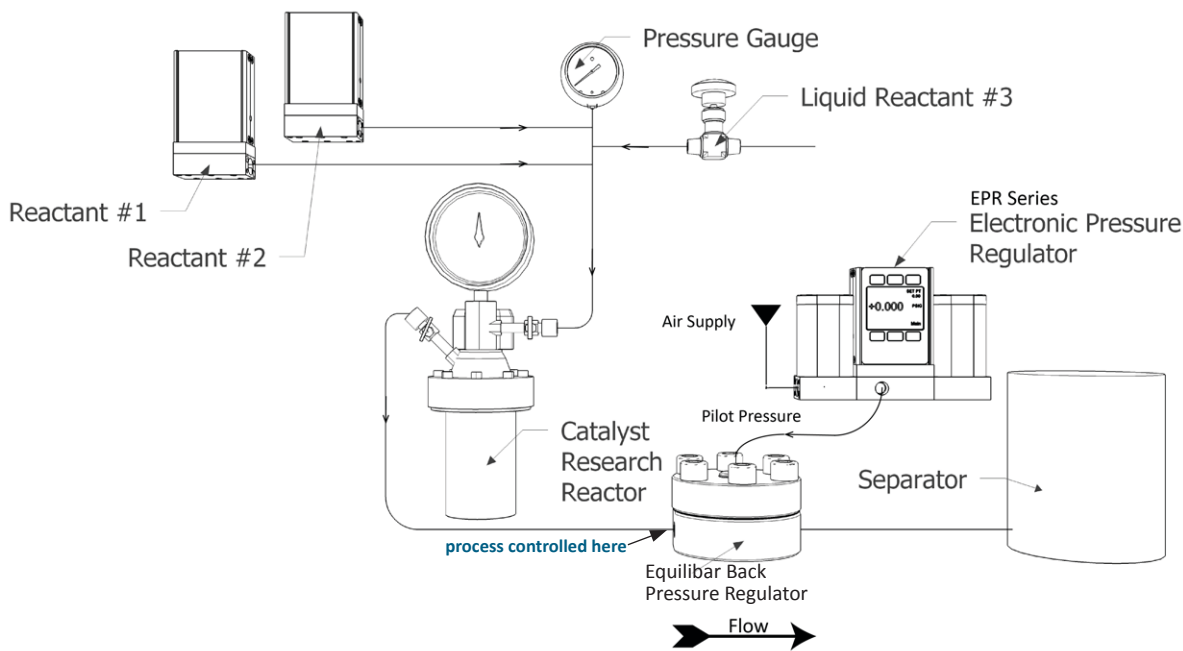

Fig. 2 Typical EPR Plumbing Diagram

# Common Applications

## CATALYST RESEARCH REACTOR CONTROL

The EPR pressure controller is designed for static to low-flow applications of inert gas such as nitrogen or air. One common application is to provide a high pressure pilot signal for dome-loaded regulators. In the schematic below, an EPR is used to control the output pressure of a catalyst research reactor. Because both the EPR and the Equilibr® back pressure regulator have no significant hysteresis or dead-band, it is possible to precisely control reaction conditions even with highly varying process flow rates.



## ELECTRONIC BACK PRESSURE CONTROL

The EPR is an excellent pilot regulator to electronically control an Equilibr® precision back pressure regulator.

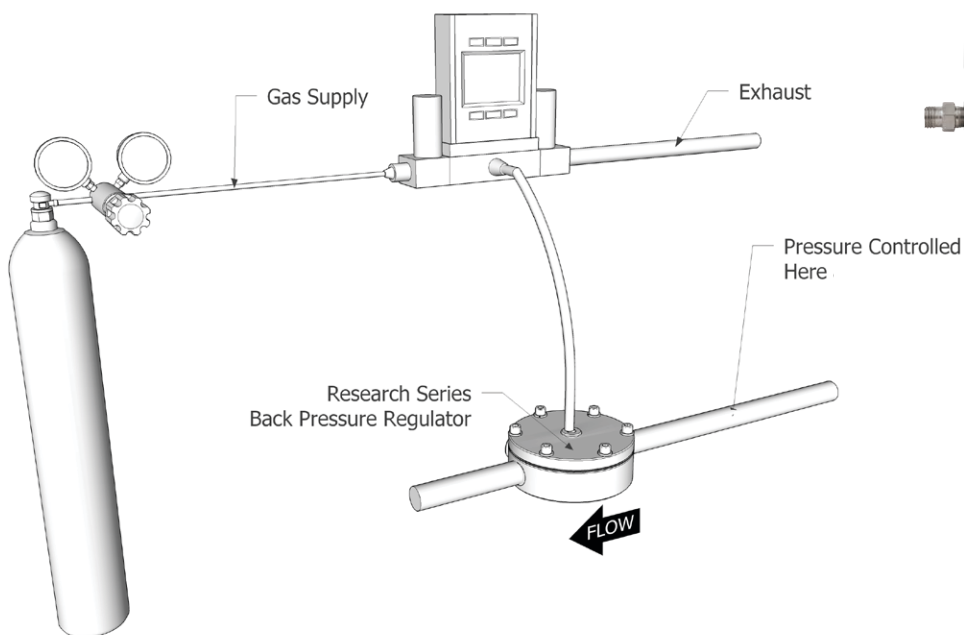

EPR 3000 pilot operating an Equilibr H3P back pressure regulator

# Key Performance Features

- Proportional inlet & outlet valves for maximum stability
- No gas wasted at steady state
- Very high resolution with 0.25% accuracy
- Digital or analog communications
- Direct control from the keypad

## General Specifications

PARAMETER	SPECIFICATION
Maximum Pressure	Models to 30inHg; 150 psig; 500 psig; 1000 psig; 3000 psig
Maximum Inlet Pressure	115% of maximum calibrated range
Full scale pressure accuracy >2"H2O	± 0.25%
Maximum Flow	50 SLPM at 3000 PSIG Supply and 1500 PSIG Setpoint
Repeatability	± 0.08% Full Scale
Zero Shift and Span Shift	0.02% Full Scale / °Celsius
Operating Range / Turndown Ratio	0.5% to 100% Full Scale / 200:1 Turndown
Excess Pressure	102.4% FS Controllable
Burst Pressure	3 X Full Scale
Typical Response Time <sup>1</sup>	100 ms (Adjustable)
Warm-up Time	< 1 Second

<sup>1</sup>Volumes, feed pressures, exhaust pressures and line sizing will determine the limits of response times.

OPERATING CONDITIONS	SPECIFICATION
Gas Compatibility	Compatible with all non-corrosive gases
Operating Temperature	-10 to +50 °Celsius
Mounting Altitude Sensitivity	None
Valve Type	Normally Closed
Ingress Protection	IP40
Wetted Materials	302 & 303 Stainless Steel, Viton®, Silicone RTV, Brass, 400 Series Stainless Steel, Silicon, Glass.

Viton® is a registered trademark of DuPont.

COMMUNICATION / POWER	SPECIFICATION
Monochrome LCD or Color TFT Display with integrated touchpad	Controls Input / Displays Pressure
Digital Input / Output Signal <sup>1</sup> Options	RS-232 Serial / RS-485 Serial / ModBus
Analog Input / Output Signal <sup>2</sup> Options	4-20 mA or 0-5 Vdc
Optional Secondary Analog Input/Output Signal <sup>2</sup>	4-20 mA or 0-5 Vdc
Electrical Connection	8 Pin Mini-DIN
Supply Voltage	24 - 30 Vdc
Supply Current	0.250 Amp

<sup>1</sup>The Digital Output Signal communicates Pressure

<sup>2</sup>The Analog Output Signal and Optional Secondary Analog Output Signal communicate Pressure

MECHANICAL SPECIFICATIONS	MECHANICAL DIMENSIONS	PROCESS CONNECTIONS
EPR 30Hg, EPR 150 and EPR 500	4.1"H x 4.8"W x 1.1"D	1/8" NPT Female
EPR 1000 and EPR 3000	4.1"H x 5.9"W x 1.1"D	1/8" NPT Female

## Ordering Information

EXAMPLE PART NUMBER	EPR	1000	E
Your Part Number:	EPR		

1 2

<b>1</b>	<b>PRESSURE RANGE</b>
<b>30Hg</b>	0 - 30 inHg Vacuum / 760 Torr
<b>150</b>	0 - 150 psig / 10 bar(g)
<b>500</b>	0 - 500 psi / 34.5 bar(g)
<b>1000</b>	0- 1000 psi / 69 bar(g)
<b>3000</b>	0 - 3000 psi / 206 bar(g)
<b>2</b>	<b>COMMAND SIGNAL</b>
<b>blank</b>	4 to 20 mA (standard)
<b>E</b>	0 to 5 Vdc (option)

# EPR Series Dimensional Drawings

## EPR 150, EPR 500 AND EPR 30HG

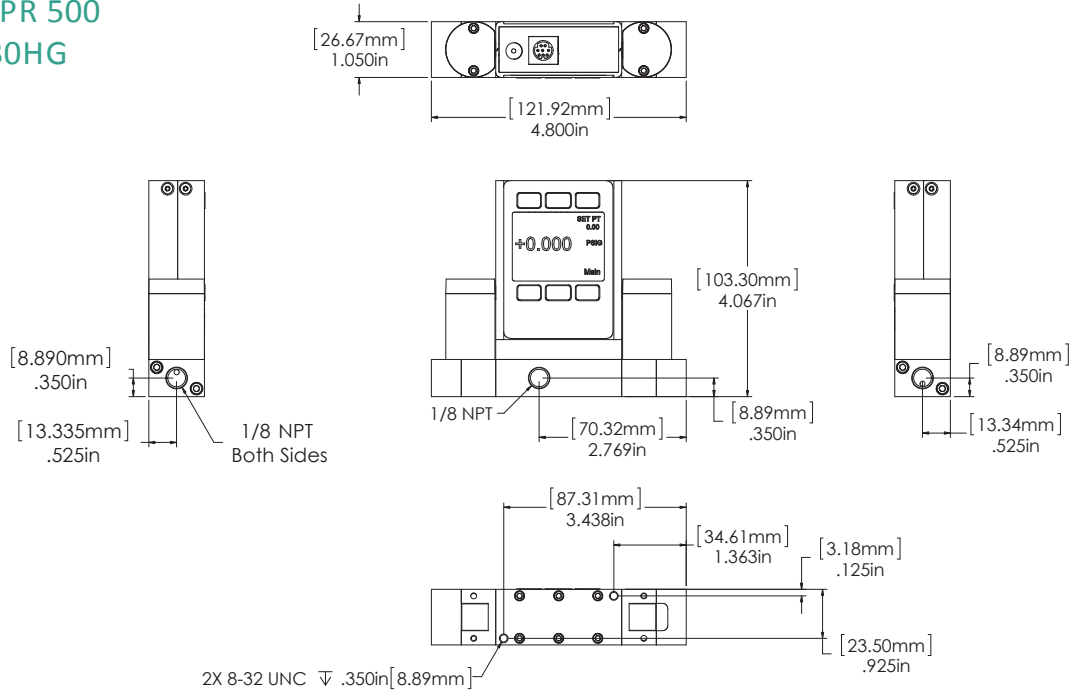

## EPR 1000 AND EPR 3000

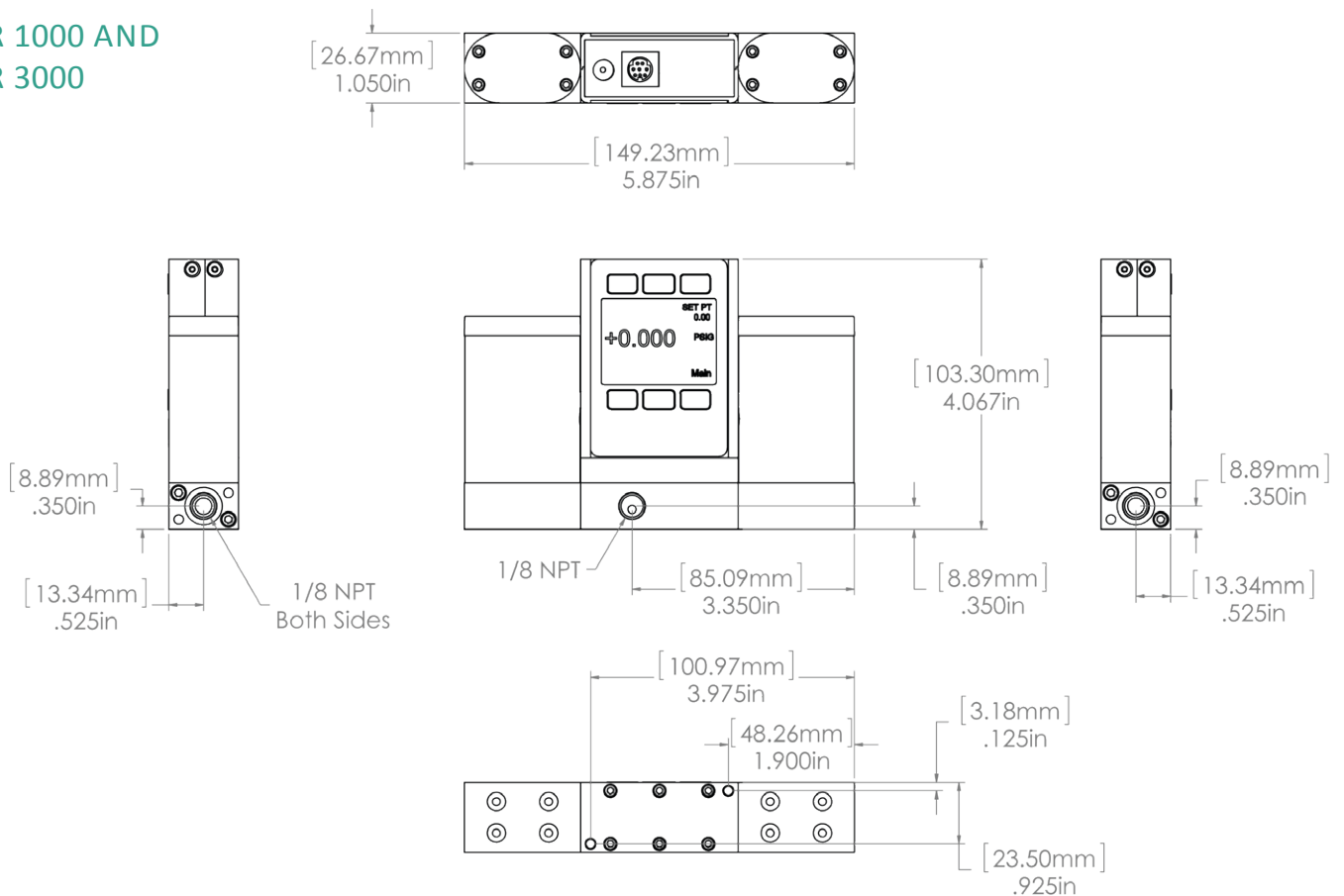

# Power & Control Options

## CONVENIENT COMMUNICATION & CONNECTIONS

The EPR Series controller can be quickly commanded using the convenient keypad interface. The EPR can be automated through either the analog interface or by use of a Serial (RS-232 or RS-485) connection. Power supply for the unit (12-30 VDC) can be provided through an included power brick, or provided through the 8 pin DIN connector.

Use the 8-Pin cable and a computer to provide an RS232 or RS485 interface

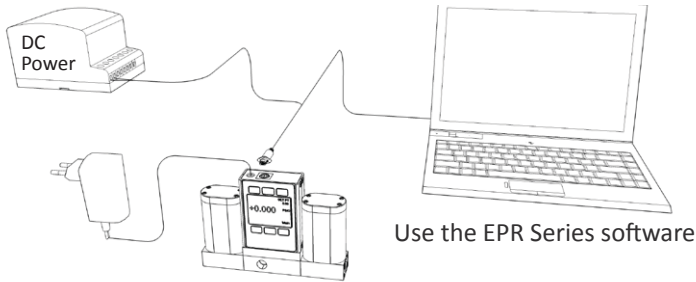

Use the AC adapter or an industrial power supply to provide DC power

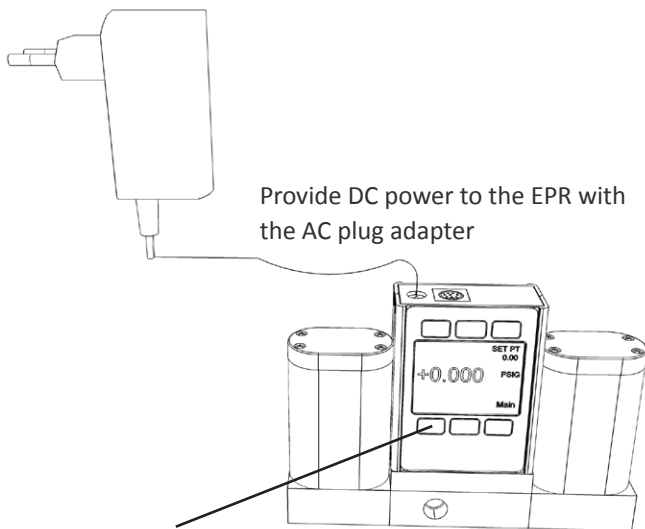
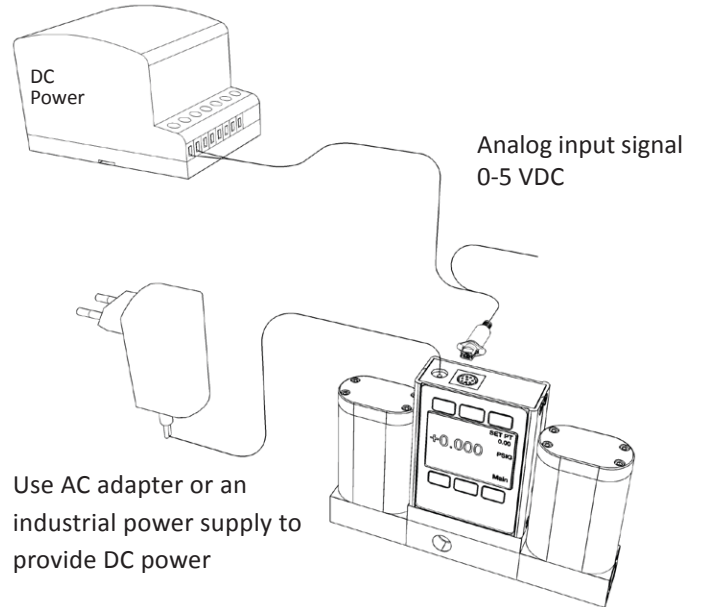

Use the push buttons and LCD screen to manually adjust the pressure

Use an industrial 24VDC power supply to provide DC power

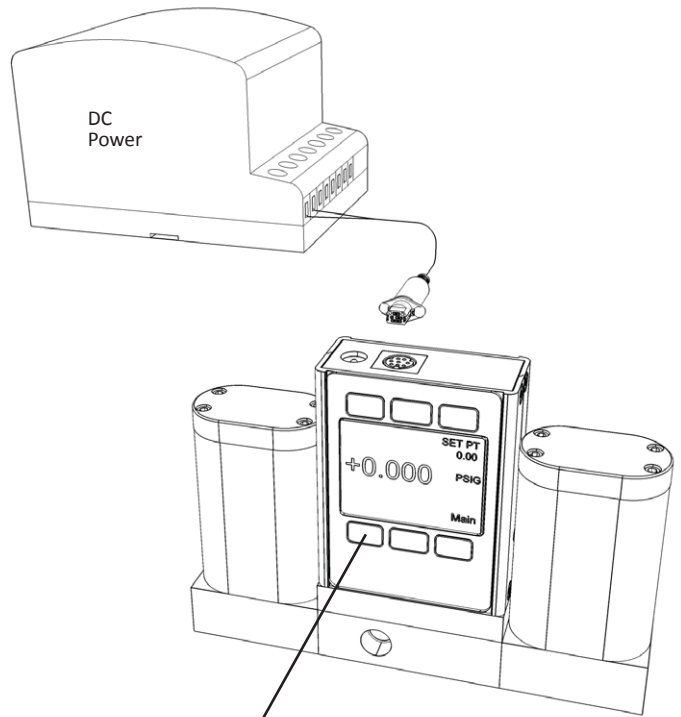

# About Equibar

Equibar provides innovative and robust pressure control technology for researchers and engineers worldwide. We are proud to design, manufacture, and test our patented back pressure regulators in our factory overlooking the Blue Ridge Mountains near Asheville, NC.

## APPLICATION ENGINEERING— WHAT SETS US APART

Unlike mass-market regulator distributors, we focus on working with you, the scientist or engineer with a complex pressure control scenario.

Our application engineers work collaboratively with clients to identify the optimal model, trim, and diaphragm for each application's unique challenges. No matter where you are on the globe, you can stay in close contact with your engineer by email, telephone, videoconferencing, or fax.

After installation, your application engineer will support you with start-up information and fine-tuning as needed.



Equibar, LLC  
320 Rutledge Rd.  
Fletcher, North Carolina 28732  
United States  
Tel: +1-828-650-6590  
Fax: +1-801-504-4439  
Monday - Friday  
8:00 AM - 5:00 PM EST  
12:00 - 21:00 GMT  
inquiry@equibar.com



Each application is reviewed by our engineering team to ensure quality performance of our products.

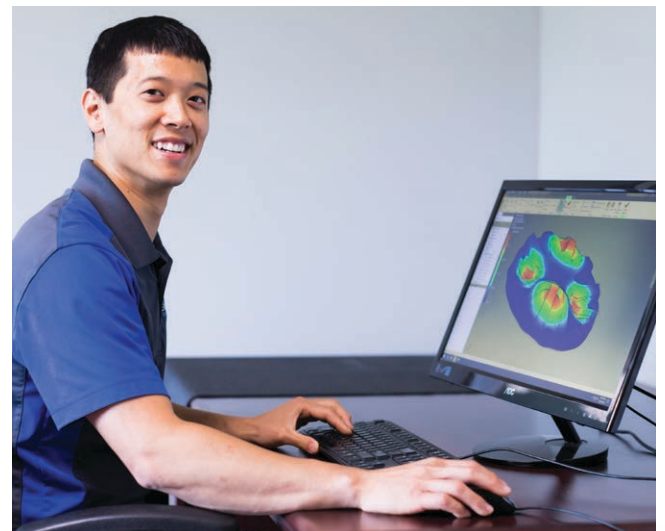

Our engineers offer custom designed solutions for the most difficult pressure control challenges. Feel free to contact us to discuss your situation.



Made in the  
**USA**

Equibar's quality system is  
**ISO 9001:2015** certified.