

Features and Benefits

- Standard trim is stellite faced seats integral to the body, 13% chrome disc, and 13% chrome stem (API trim 8). Other trims available on request.
- Wall thickness per heavy wall API 602 requirements.
- Seat faces coined for smooth finish and superior sealing.
- Swivel disc for optimal seating and longer seat life are non-rotating.
- Stems of hand wheel operated design are rotating/ rising design.
- Each valve is shell, seat and backseat pressure tested per industry standard API 598.
- Gland flange design for optimal alignment and uniform packing compression.
- End Flanges have the following raised faces per ASME B16.5:
 - Classes 150-300: 1/16" (2mm)
 - Classes 600: 1/4" (7mm)
- Weld ends are available per ASME B16.25/B16.11 or per customer's specification.
- Other available options as follows:
 - Alternate valve materials such as chrome and stainless steel alloys
 - Alternate trim materials
 - NACE service
 - Special cleaning for applications such as oxygen or chlorine
 - Other options available as specified



Design Specifications

Item	Applicable Specification
Wall thickness	API 602
Pressure - temperature ratings	ASME B16.34
General valve design	API 602 & B16.34
End to End dimensions	ASME B16.10
Flange design	ASME B16.5
Thread design	ASME B1.20.1
Butt Weld design	ASME B16.25
Socket Weld design	ASME B16.11
Materials	ASTM

Class	Bore	Fig. No.
150	Standard	HGP01
	Full	HGPL1
300	Standard	HGP03
	Full	HGPL3
600	Standard	HGP06
	Full	HGPL6
800	Standard	HGP08
	Full	HGPL8
1500	Standard	HGP15
	Full	HGPL5
2500	Standard	HGP25

Standard Materials (Other Materials Available)

Part	Materials				
Body	A105 + Stellite 6 Faced	A182 F11 + Stellite 6 Faced	A182 F22 + Stellite 6 Faced	A182 F91 + Stellite 6 Faced	A182F316 (1)
Bonnet	A105	A182 F11	A182 F22	A182 F91	A182 F316
Disc	SST 410				A182 F316
Stem	A182 F6a				A182 F316
Gland Flange	A105				Series 300 SST
Eye Bolt	A193 Gr. B7	A193 Gr. B16			A193 Gr. B8M
Eye Bolt Nut	A194 Gr. 2H	A194 Gr. 7			A194 Gr. 8M
Gland	SST 420				SST 316
Packing	Graphite				
Gasket (2)	Spiral Wound SST with Graphite				
Hand Wheel	Malleable Iron or Steel				
Hand Wheel Nut	Malleable Iron or Steel				
Body / Bonnet Bolting (2)	A193 Gr. B7	A193 Gr. B16			A193 Gr. B8M
Identification Plate	Series 300 SST				

(1) Threaded and weld end valve bodies A182 F316L

(2) Welded bonnet design also available.

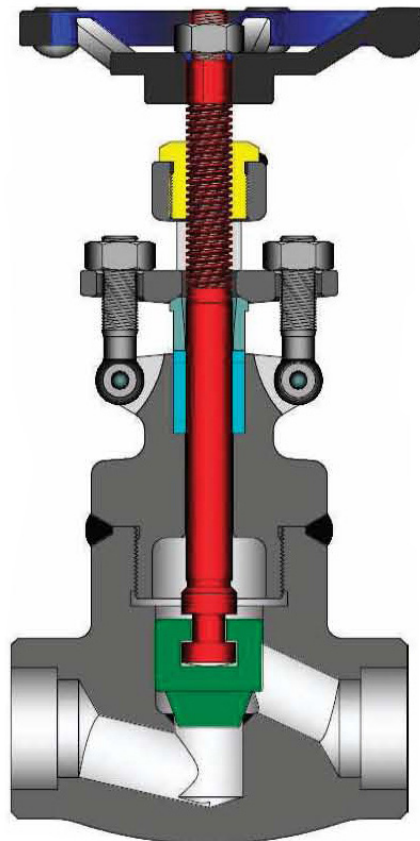

Welded Bonnet Design

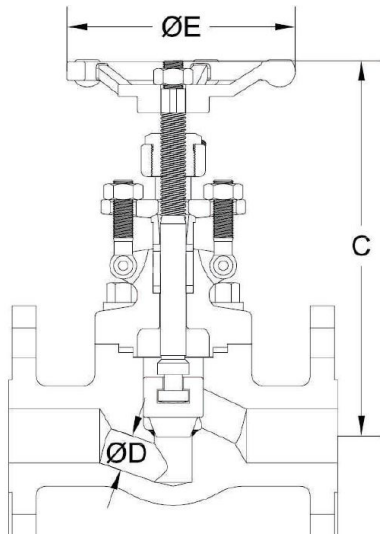
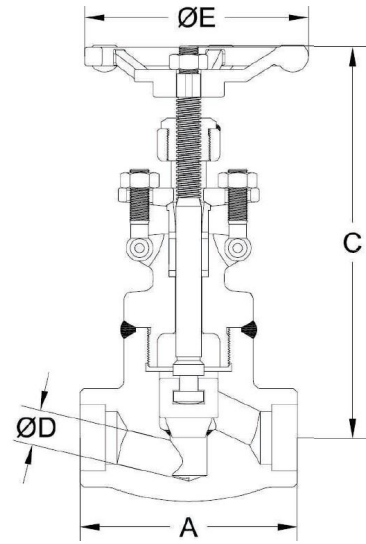
Dimensions

Bolted Bonnet Flanged Ends Design

Welded Bonnet Socket Weld Ends Design

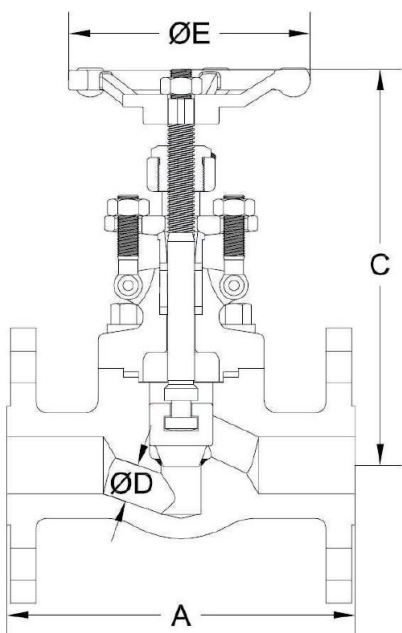
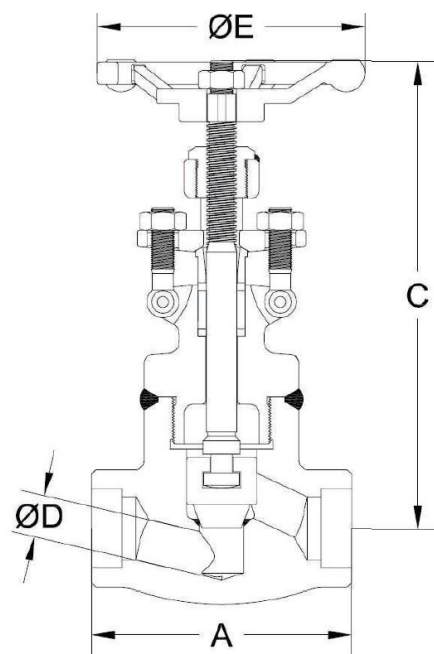
Size	ASME 150				ASME 300				ASME 600			
	Bolted Bonnet				Bolted Bonnet				Bolted Bonnet			
	Standard Bore				Standard Bore				Standard Bore			
in	A FE	C	D	E	A FE	C	D	E	A FE	C	D	E
1/2	4.25	6.0	0.50	3.9	5.50	6.0	0.50	3.9	6.50	6.0	0.50	3.9
3/4	4.62	6.0	0.50	3.9	6.00	6.0	0.50	3.9	7.50	6.0	0.50	3.9
1	5.00	7.3	0.71	4.9	6.50	7.3	0.71	4.9	8.50	7.3	0.71	4.9
1 1/4	5.50	8.7	0.94	6.3	7.00	8.7	0.94	6.3	9.00	8.7	0.94	6.3
1 1/2	6.50	9.4	1.14	6.3	7.50	9.4	1.14	6.3	9.50	9.4	1.14	6.3
2	7.00	11.0	1.46	7.1	8.50	11.0	1.46	7.1	11.50	11.0	1.46	7.1

Size	ASME 800															
	Bolted Bonnet								Welded Bonnet							
	Standard Bore				Full Bore				Standard Bore				Full Bore			
in	A WE	C	D	E	A WE	C	D	E	A WE	C	D	E	A WE	C	D	E
1/4	3.11	6.1	0.26	3.9	-	-	-	-	3.11	6.1	0.26	3.9	-	-	-	-
3/8	3.11	6.1	0.39	3.9	-	-	-	-	3.11	6.1	0.39	3.9	-	-	-	-
1/2	3.11	6.2	0.39	3.9	3.62	6.2	0.50	6.3	3.11	6.1	0.39	3.9	3.62	6.2	0.50	3.9
3/4	3.62	6.2	0.50	3.9	4.37	7.6	0.69	4.9	3.62	6.2	0.50	3.9	4.37	7.6	0.69	4.9
1	4.37	7.6	0.69	4.9	4.72	8.9	0.91	6.3	4.37	7.6	0.69	4.9	4.72	8.9	0.91	6.3
1 1/4	4.72	8.9	0.91	6.3	5.98	9.4	1.12	6.3	4.72	8.9	0.91	6.3	5.98	9.4	1.12	6.3
1 1/2	5.98	9.4	1.12	6.3	6.77	11.0	1.40	7.1	5.98	9.4	1.12	6.3	6.77	11.0	1.42	7.1
2	6.77	11.0	1.38	7.1	8.66	12.8	1.85	7.9	6.77	11.0	1.38	7.1	8.66	12.8	1.85	7.9

Dimensions

Bolted Bonnet Flanged Ends Design

Welded Bonnet Socket Weld Ends Design

Size	ASME 1500																
	Bolted Bonnet									Welded Bonnet							
	Standard Bore					Full Bore				Standard Bore				Full Bore			
in	A		C	D	E	A	C	D	E	A	C	D	E	A	C	D	E
	FE	WE															
1/4	-	3.11	6.9	0.26	3.9	-	-	-	-	3.11	6.2	0.39	3.9	-	-	-	-
3/8	-	3.62	7.0	0.39	3.9	-	-	-	-	3.62	6.2	0.50	3.9	-	-	-	-
1/2	8.50	3.62	7.4	0.39	3.9	4.37	7.4	0.50	4.9	4.37	7.4	0.39	4.9	4.37	7.4	0.50	4.9
3/4	9.00	4.37	7.4	0.50	3.9	4.72	8.9	0.69	6.3	4.37	7.4	0.50	4.9	4.72	8.9	0.69	6.3
1	10.00	4.72	8.9	0.69	4.9	5.98	9.5	0.91	6.3	4.72	8.9	0.69	6.3	5.98	9.5	0.91	6.3
1 1/4	11.00	5.98	9.5	0.91	6.3	6.77	10.9	1.12	7.1	5.98	9.5	0.91	6.3	6.77	10.9	1.12	7.1
1 1/2	12.00	6.77	10.9	1.12	6.3	8.66	12.8	1.38	7.9	6.77	10.9	1.12	7.1	8.66	12.8	1.38	7.9
2	14.50	8.66	12.8	1.38	7.1	9.84	14.0	1.85	7.9	8.66	12.8	1.38	7.9	9.84	14.0	1.85	7.9

Dimensions

Size	ASME 150			ASME 300			ASME 600			ASME 800											
	Bolted Bonnet			Bolted Bonnet			Bolted Bonnet			Bolted Bonnet						Bolted Bonnet					
	Standard Bore			Standard Bore			Standard Bore			Standard Bore			Full Bore			Standard Bore			Full Bore		
in	WT FE	LB KG	Cv	WT FE	LB KG	Cv	WT FE	LB KG	Cv	WT WE	LB KG	Cv	WT WE	LB KG	Cv	WT WE	LB KG	Cv	WT WE	LB KG	Cv
1/4	-	-	-	-	-	-	-	-	-	4.6	0.7	-	-	4.4	0.7	-	-	-	-	-	
3/8	-	-	-	-	-	-	-	-	-	4.6	1.5	-	-	4.4	1.5	-	-	-	-	-	
1/2	9.9	1.5	10.6	1.5	12.3	1.5	4.4	1.5	4.9	2.6	4.2	1.5	4.6	2.6	8.2	5.1	11.9	8.9	8.9		
3/4	15.2	2.7	17.0	2.7	17.2	2.7	4.9	2.7	8.4	4.9	4.6	2.7	8.2	4.9	11.9	8.9	11.9	8.9	8.9		
1	21.6	5.1	24.3	5.1	27.6	5.1	5.5	5.1	12.1	8.9	8.2	5.1	11.9	8.9	11.9	8.9	11.9	8.9	8.9		
1 1/4	29.8	9.1	37.0	9.1	37.5	9.1	12.1	9.1	15.4	13.7	11.9	9.1	15.2	13.7	15.2	13.7	15.2	13.7	13.7		
1 1/2	43.0	14.0	46.5	14.0	51.8	14.0	15.4	14.0	25.4	21.9	15.2	14.0	25.1	21.9	25.1	21.9	25.1	21.9	21.9		
2	61.7	22.4	68.0	22.4	71.9	22.4	25.4	22.4	26.5	40	25.1	22.4	26.2	40	26.2	40	26.2	40	40		

Size	ASME 1500												ASME 2500 & 2680							
	Bolted Bonnet						Welded Bonnet						Bolted Bonnet			Welded Bonnet				
	Standard Bore			Full Bore			Standard Bore			Full Bore			Standard Bore			Standard Bore				
in	WT FE	LB KG	WT FE	LB KG	Cv	WT WE	LB KG	Cv	WT WE	LB KG	Cv	WT WE	LB KG	Cv	WT WE	LB KG	Cv	WT WE	LB KG	Cv
1/4	-	-	6.6	0.7	-	-	-	-	6.2	0.7	-	-	-	-	-	-	-	-	-	
3/8	-	-	7.7	1.5	-	-	-	-	6.6	1.5	-	-	-	-	-	-	-	-	-	
1/2	24.3	1.5	7.7	1.5	8.8	1.5	7.3	1.5	8.6	1.5	23.8	1.8	16.1	3.0	26.8	3.2	27.6	6.0		
3/4	29.1	2.7	8.8	2.7	13.9	2.7	8.4	2.7	13.7	2.7	24.3	1.9	18.7	3.1	26.8	3.2	27.6	6.0		
1	38.4	5.1	13.9	5.1	17.6	5.1	13.4	5.1	17.4	5.1	26.8	3.2	27.6	6.0	26.8	3.2	27.6	6.0		
1 1/4	41.9	9.1	17.6	9.1	27.6	9.1	17.2	9.1	27.3	9.1	47.8	4.3	45.6	10.5	47.8	4.3	45.6	10.5		
1 1/2	54.0	14.0	27.6	14.0	43.0	14.0	27.1	14.0	42.8	14.0	48.5	10.7	46.3	13.5	48.5	10.7	46.3	13.5		
2	85.5	22.4	43.0	22.4	44.1	22.4	42.5	22.4	43.9	22.4	81.6	14.2	79.4	22.4	81.6	14.2	79.4	22.4		

Pressure and Temperature Ratings

ASME B16.34-2009			
Ratings for Group Materials			
A 105 (1)(2)	A 515 Gr. 70 (1)	A 696 Gr. C (5)	A 672 Gr. B70 (1)
A 216 Gr. WCB (1)	A 516 Gr. 70 (1)(3)	A 350 Gr. LF6 Cl. 1 (4)	A 672 Gr. C70 (1)
A 350 Gr. LF2 (1)	A 537 Cl. 1 (5)	A 350 Gr. LF3 (6)	

(1) - Upon prolonged exposure to temperatures above 800°F, the carbide phase of steel may be converted to graphite. Permissible, but not recommended for prolonged use above 800 °F

(2)- Only Killed steel shall be used above 850 °F.

(3)- Not to be used over 850 °F.

(4)- Not to be used over 500 °F.

(5)- Not to be used over 700 °F.

(6)- Not to be used over 650 °F.

Standard Class						
Working Pressure by Class, psig						
Temperature F° (C°)	150	300	600	900	1500	2500
-20 to 100 (-29 - 38)	285	740	1,480	2,220	3,705	6,170
200 (93)	260	680	1,360	2,035	3,395	5,655
300 (149)	230	655	1,310	1,965	3,270	5,450
400 (204)	200	635	1,265	1,900	3,170	5,280
500 (260)	170	605	1,205	1,810	3,015	5,025
600 (316)	140	570	1,135	1,705	2,840	4,730
650 (343)	125	550	1,100	1,650	2,745	4,575
700 (371)	110	530	1,060	1,590	2,665	4,425
750 (399)	95	505	1,015	1,520	2,535	4,230
800 (427)	80	410	825	1,235	2,055	3,430
850 (454)	65	320	640	955	1,595	2,655
900 (482)	50	230	460	690	1,150	1,915
950 (510)	35	135	275	410	685	1,145
1,000 (538)	20	85	170	255	430	715
Special Class						
Working Pressure by Class, psig						
Temperature F° (C°)	150	300	600	900	1500	2500
-20 to 100 (-29 - 38)	290	750	1,500	2,250	3,750	6,250
200 (93)	290	750	1,500	2,250	3,750	6,250
300 (149)	285	740	1,480	2,220	3,700	6,170
400 (204)	280	735	1,465	2,200	3,665	6,105
500 (260)	280	735	1,465	2,220	3,665	6,105
600 (316)	280	735	1,465	2,220	3,665	6,105
650 (343)	275	715	1,430	2,145	3,575	5,960
700 (371)	265	390	1,380	2,075	3,455	5,760
750 (399)	245	635	1,270	1,905	3,170	5,285
800 (427)	195	515	1,030	1,545	2,570	4,285
850 (454)	155	400	795	1,195	1,995	3,320
900 (482)	110	285	475	860	1,435	2,395
950 (510)	65	170	345	515	855	1,430
1,000 (538)	40	105,1,5	215	320	535	895

Pressure and Temperature Ratings

ASME B16.34-2009			
Ratings for Group Materials			
A 182 Gr. F91	A 217 Gr. C12A (1)	A 387 Gr. 91 Cl. 2	A 335 Gr. P91

NOTE:

(1) - The deliberate addition of any element not listed in ASTM A 217, Table 1 is prohibited, except that Ca and Mg may be added for detoxidation.

Standard Class						
Working Pressure by Class, psig						
Temperature F° (C°)	150	300	600	900	1500	2500
-20 to 100 (-29 - 38)	290	750	1,500	2,250	3,750	6,250
200 (93)	260	750	1,500	2,250	3,750	6,250
300 (149)	230	730	1,455	2,185	3,640	6,070
400 (204)	200	705	1,410	2,115	3,530	5,880
500 (260)	170	665	1,330	1,995	3,325	5,540
600 (316)	140	605	1,210	1,815	3,025	5,040
650 (343)	125	590	1,175	1,765	2,940	4,905
700 (371)	110	570	1,135	1,705	2,840	4,730
750 (399)	95	530	1,065	1,595	2,660	4,430
800 (427)	80	510	1,015	1,525	2,540	4,230
850 (454)	65	485	975	1,460	2,435	4,060
900 (482)	50	450	900	1,350	2,245	3,745
950 (510)	35	385	775	1,160	1,930	3,220
1,000 (538)	20	365	725	1,090	1,820	3,030
1,050 (566)	20 (a)	360	720	1,080	1,800	3,000
1,100 (593)	20 (a)	300	605	905	1,510	2,515
1,150 (621)	20 (a)	225	445	670	1,115	1,855
1,200 (649)	20 (a)	145	290	430	720	1,200

GENERAL NOTE:

(1) - Flanged-end valve ratings terminate at 1,000°F.

Special Class						
Working Pressure by Class, psig						
Temperature F° (C°)	150	300	600	900	1500	2500
-20 to 100 (-29 - 38)	290	750	1,500	2,250	3,750	6,250
200 (93)	290	750	1,500	2,250	3,750	6,250
300 (149)	290	750	1,500	2,250	3,750	6,250
400 (204)	290	750	1,500	2,250	3,750	6,250
500 (260)	290	750	1,500	2,250	3,750	6,250
600 (316)	290	750	1,500	2,250	3,750	6,250
650 (343)	290	750	1,500	2,250	3,750	6,250
700 (371)	280	735	1,465	2,200	3,750	6,250
750 (399)	280	730	1,460	2,160	3,600	6,000
800 (427)	275	720	1,440	2,160	3,600	6,000
850 (454)	260	680	1,355	2,030	3,385	5,645
900 (482)	230	600	1,200	1,800	3,000	5,000
950 (510)	180	470	945	1,415	2,360	3,930
1,000 (538)	160	420	840	1,260	2,105	3,505
1,050 (566)	160	420	840	1,260	2,105	3,505
1,100 (593)	145	375	755	1,130	1,885	3,145
1,150 (621)	105	280	555	835	1,395	2,320
1,200 (649)	70	180	360	540	900	1,500

Pressure and Temperature Ratings

ASME B16.34-2009			
Ratings for Group Materials			
A 182 Gr. F22 Cl. 3 (1)	A 217 Gr. WC9 (2)(3)(4)	A 387 Gr. 22 Cl. 2 (1)	A 739 Gr. B22 (2)

NOTES:

- (1) - Permissible, but not recommended for prolonged use above 1,100°F.
- (2) - Use normalized and tempered material only.
- (3) - Not to be used over 1,100°F.
- (4) - The deliberate addition of any element not listed in ASTM A 217, Table 1 is prohibited, except that Ca and Mg may be added for detoxidation.

Standard Class						
Working Pressure by Class, psig						
Temperature F° (C°)	150	300	600	900	1500	2500
-20 to 100 (-29 - 38)	290	750	1,500	2,250	3,750	6,250
200 (93)	260	750	1,500	2,250	3,750	6,250
300 (149)	230	730	1,455	2,185	3,640	6,070
400 (204)	200	705	1,410	2,115	3,530	5,880
500 (260)	170	665	1,330	1,995	3,325	5,540
600 (316)	140	605	1,210	1,815	3,025	5,040
650 (343)	125	590	1,175	1,765	2,940	4,905
700 (371)	110	570	1,135	1,705	2,840	4,730
750 (399)	95	530	1,065	1,595	2,660	4,430
800 (427)	80	510	1,015	1,525	2,540	4,230
850 (454)	65	485	975	1,460	2,435	4,060
900 (482)	50	450	900	1,350	2,245	3,745
950 (510)	35	385	775	1,160	1,930	3,220
1,000 (538)	20	265	535	800	1,335	2,230
1,050 (566)	20 (a)	175	350	525	875	1,455
1,100 (593)	20 (a)	110	220	330	550	915
1,150 (621)	20 (a)	70	135	205	345	570
1,200 (649)	15 (a)	40	80	125	205	345

GENERAL NOTE:

- (1) - Flanged-end valve ratings terminate at 1,000°F.

Special Class						
Working Pressure by Class, psig						
Temperature F° (C°)	150	300	600	900	1500	2500
-20 to 100 (-29 - 38)	290	750	1,500	2,250	3,750	6,250
200 (93)	290	750	1,500	2,250	3,750	6,250
300 (149)	285	740	1,480	2,250	3,695	6,160
400 (204)	280	730	1,455	2,185	3,640	6,065
500 (260)	280	725	1,450	2,175	3,620	6,035
600 (316)	275	720	1,440	2,165	3,605	6,010
650 (343)	275	715	1,430	2,145	3,580	5,965
700 (371)	270	705	1,415	2,120	3,535	5,895
750 (399)	270	705	1,415	2,120	3,535	5,895
800 (427)	270	705	1,415	2,120	3,535	5,895
850 (454)	260	680	1,355	2,030	3,385	5,645
900 (482)	230	600	1,200	1,800	3,000	5,000
950 (510)	180	470	945	1,415	2,360	3,930
1,000 (538)	130	335	670	1,005	1,670	2,785
1,050 (566)	85	220	435	655	1,095	1,820
1,100 (593)	55	135	275	410	685	1,145
1,150 (621)	35	85	170	255	430	715
1,200 (649)	20	50	105	155	255	430

Pressure and Temperature Ratings

ASME B16.34-2009			
Ratings for Group Materials			
A 182 Gr. F316 (1)	A 240 Gr. 317H	A 351 Gr. CF8M (1)	A 376 Gr. TP316 (1)
A 182 Gr. F316H	A 312 Gr. TP316	A 351 Gr. CF8A (2)	A 376 Gr. TP316H
A 182 Gr. F317 (1)	A 312 Gr. TP316H	A 351 Gr. CF10M	A 430 Gr. FP316 (1)
A 182 Gr. F317H	A 312 Gr. TP317 (1)	A 351 Gr. CG3M (3)	A 430 Gr. FP316H
A 240 Gr. 316 (1)	A 312 Gr. TP317H	A 351 Gr. CG8M (4)	A479 Gr. 316 (1)
A 240 Gr. 316H	A 351 Gr. CF3A (2)	A 358 Gr. 316 (1)	A 479 Gr. 316H
A 240 Fr. 317			

NOTES:

(1)- At temperatures over 1,000°F, use only when the carbon content is 0.04% or higher.

(2)- Not to be used over 650°F.

(3)- Not to be used over 850 °F.

(4)- Not to be used over 1,000 °F.

Standard Class						
Working Pressure by Class, psig						
Temperature F° (C°)	150	300	600	900	1500	2500
-20 to 100 (-29 - 38)	275	720	1,440	2,160	3,600	6,000
200 (93)	235	620	1,240	1,860	3,095	5,160
300 (149)	215	560	1,120	1,680	2,795	4,660
400 (204)	195	515	1,025	1,540	2,570	4,280
500 (260)	170	480	955	1,435	2,390	3,980
600 (316)	140	450	900	1,355	2,255	3,760
650 (343)	125	440	885	1,325	2,210	3,680
700 (371)	110	435	870	1,305	2,170	3,620
750 (399)	95	425	855	1,280	2,135	3,560
800 (427)	80	420	845	1,265	2,110	3,520
850 (454)	65	420	835	1,255	2,090	3,480
900 (482)	50	415	830	1,245	2,075	3,460
950 (510)	35	385	775	1,160	1,930	3,220
1,000 (538)	20	365	725	1,090	1,820	3,030
1,050 (566)	20	360	720	1,080	1,800	3,000
1,100 (593)	20 (a)	305	610	915	1,525	2,545
1,150 (621)	20 (a)	235	475	710	1,185	1,970
1,200 (649)	20 (a)	185	370	555	925	1,545
1,250 (677)	20 (a)	145	295	440	735	1,230
1,300 (704)	20 (a)	95	190	290	480	800
1,350 (732)	20 (a)	95	190	290	480	800
1,400 (760)	20 (a)	75	150	225	380	630
1,450 (788)	20 (a)	60	115	175	290	485
1,500 (816)	15 (a)	40	85	125	205	345

GENERAL NOTE:

(a)- Flanged-end valve ratings terminate at 1,000°F.



Globe Valves

HGP Series

HGP Series/091F

Ordering Schematic

1	2	3	4	5	6	7	8	9	10	11	12	13	14
Series		Size		Type	Pressure Class			Ends	Material	Trim	P&G	Bonnet	
H	G	P	3	G	L	0	1	T	A	5	8	G	B

Example:

4	Size
3	1/2
4	3/4
5	1
6	1 1/2
7	2

5-6	Type
GL	Globe

7-8	Pressure Class
01	Standard Port 150#
L1	Full Port 150#
03	Standard Port 300#
L3	Full Port 300#
06	Standard Port 600#
L6	Full Port 600#
08	Standard Port 800#

7-8	Pressure Class
L8	Full Port 800#
15	Standard Port 1500#
L5	Full Port 1500#
16	Standard Port 1690#
L7	Full Port 1690#
25	2500#
26	2680#

9	Ends
T	Threaded
S	Socketweld
F	Flanged
R	Ring Joint
Y	Inlet Th X Outlet Sw
Z	Inlet Sw X Outlet Th

10-11	Material
A5	A105
04	A182 304
16	A182 316
21	A182 321
47	A182 347
4H	A182 304H
4L	A182 304L
6L	A182 316L
L2	A350-LF2
A2	Alloy 20
40	Alloy N04400
F1	A182 F11
F2	A182 F22
F4	A182 F44

10-11	Material
F5	A182 F5
51	A182 F51
F3	A182 F53
55	A182 F55
F9	A182 F9
91	A182 F91
C2	Hastelloy
80	Incoloy 800H
82	Incoloy 825
62	Inconel 625
17	A182 317
7L	A182 317L

12	Trim
0	API Trim 10
1	API Trim 1
2	API Trim 12
3	API Trim 13
5	API Trim 5
6	API Trim 16
8	API Trim 8
9	API Trim 9
A	Base Metal w/ Half Hard Facing
B	Base Metal w/ Full Hard Facing
C	Base Metal
D	API Trim 11
E	API Trim 2
N	API Trim 8 (NACE)[1]
K	Std Cryo trim w/ PCTFE disc insert
P	Std Cryo trim
G	Std Cryo trim w/ GTFE disc insert
Z	Special Trim

13	Packing & Gasket
G	Manuf. STD Graphite
T	Manuf. STD Teflon

14	Bonnet And Bolting
W	Welded Bonnet
B	Bolted Bonnet Std. Bolting
C	Bolted Bonnet w/A193 B8M Cl.2 and A194 8M
D	Bolted Bonnet w/A193 B8 Cl.2 and A194 8
E	Bolted Bonnet A193 B8M and A194 8M
F	Bolted Bonnet, Std. Bolting, Clean for Oxygen
N	Bolted Bonnet w/ A193 B7M and A194 2HM (NACE)[1]
G	Std. Extended Bolted Bonnet, Std. Bolting, Clean for Oxygen
H	Std. Extended Welded Bonnet, Clean for Oxygen
J	Welded Bonnet, Clean for Oxygen
L	Bolted Bonnet, Locking Device
K	Welded Bonnet (NACE)[1]
M	Bolted Bonnet A193 B8 and A194 8 (NACE)[1]
R	Ring Joint Bonnet.

1. API Trim 10 or 12 can also be used for NACE service valves. If Bonnet And Bolting codes N, K, or M are Selected. Make Sure to select A NACE Bonnet and Bolting Designation if a NACE valve is required.