

JSBLP Series

Compact, High Purity, Low Set Point Back Pressure Regulator

J-Pure is the first compact, back pressure regulator designed and built specifically for hygienic, ASME BPE low pressure stainless, or single use gas applications.

Traditionally, small diaphragm back pressure regulators (and PRV's) were designed to operate with set pressures down to about 5 psig (345 mbar) minimum. Below that setpoint control is unstable. The JSBLP is the first small body, large diaphragm back pressure regulator designed to operate with set points down to 1 psig (69 mbar).

- It's been designed specifically to eliminate all threaded connections and contaminant traps below the diaphragm.
- The simple trim design facilitates quick trim change out and cleaning without valve removal.

The durable valve body and metal trim components are machined from ASTM A479 316L SST barstock and finished to ASME BPE SF5 (20Ra micro-inch (0,5 Ra μ m), electropolished) standard. The valve is outfitted with the rugged Jorlon diaphragm and Teflon or PEEK seats, all FDA approved, USP Class VI compliant materials. These materials of construction enable the JSB to withstand the rigors of continuous SIP and CIP processes if required.

FEATURES

- Wide diaphragm with increased sensitivity allows for extremely low set points
- Proprietary Jorlon diaphragm material provides exceptionally long life and CIP/SIP capability, and FDA and USP Class VI compliance
- No threaded connections, or contaminant traps below the diaphragm
- In-line removable trim significantly reduces maintenance time
- Barstock construction guarantees material integrity and surface finish
- High flow rate coupled with high rangeability
- Soft seat material for ANSI Class VI shutoff

DOCUMENTATION

The following documentation is shipped at no charge:

- Steriflow Unicert, a QC signed Certificate of Compliance for:
 - Material, listing heat numbers with attached MTR's
 - Surface Finish
 - FDA/USP Class VI - for all thermoplastic and elastomers
- Traceability:
 - Each individual product serial number is traceable to the Unicert serial number, heat numbers and attached MTR's

Other documents must be requested at time of RFQ, or order:

- ADI/TSE Free, Certified Test reports, Certificate of Origin.



APPLICATIONS

The JSBLP is a back pressure regulator ideal for low flow, low pressure precision venting of clean compressed air and gas used in pharmaceutical and biopharmaceutical R&D, Pilot, and Production facilities.

It is designed specifically for use on traditional Stainless Steel and Single Use Disposable applications including:

- Small sterile vessels:
 - Gas overlay (blanketing)
 - Sparging,
 - SUD bag integrity testing/inflation
- Incubators
- Lyophilizers
- Time/pres filling machine product hold vessels

Suitable for clean compressed gas, including:

- Air
- Nitrogen
- Carbon Dioxide
- Oxygen
- Argon
- Custom gas mixtures

SPECIFICATIONS

Sizes: 1/2" (DN15) & 3/4" (DN20)

Ends: Clamp, Tube Weld End or NPT ends

Soft Seat Materials for ANSI Class VI Shut-Off:

- PTFE to +252°F (122°C) continuous or 275°F (135°C) intermittent [not to exceed 15 min. in a one hour period] FDA, USP Class VI
- PEEK to +350°F (176,7°C) FDA, USP Class VI

Body and Wetted Trim Material: ASME SA479 316L (UNS 31603) is standard. EN 10272:2000 GR 1.4435, AL-6XN®, Hastelloy®C-22 and others are optional.

Diaphragm Material: PTFE-based Jorlon; FDA, USP Class VI

Maximum Inlet Pressure: 150 psig (10,5 bar)

Spring Ranges: 1 - 15 PSI (0,07 – 1,03 bar), 5 - 15 PSI (0,34 – 1,03 bar), 15 - 25 PSI (1,03 – 1,72), 25 - 50 PSI (1,72 – 3,45)

Optional Cleaning Specifications:

- Clean for Oil-Free
- O2 Cleaning complying with ASTM G93-03 2011 and CGA G-4.1-2009

Flow Capacity - Cv (Kv)

- High Flow: Trim Cv 0.8 (Kv 0,7)
- Low Flow: Trim Cv 0.5 (Kv 0,43)

Failure - Cv (Kv)

- High Flow: Cv 0.96 (Kv 0,83)
- Low Flow: Cv 0.6 (Kv 5,2)

Surface Finish:

- Wetted Internal surface finish: Mechanically polished, and electropolished to ASME BPE SF5, 20 Ra µin (0.5 Ra µm) as standard*
- Exterior surface finish: Mechanically polished, and electropolished to 40 Ra µin (1.0 Ra µm) as standard
- Other finishes available upon request

Options:

- Panel Mounting
- Inlet-Outlet Gauge
- Air Augment

Note: For a complete ancillary list of all wetted and non-wetted material specifications, please contact Steriflow Valve.

* NPT treaded end valves: Threads are not 20 Ra (0.5 Ra). Bottom of outlet cavities (inlet, outlet, or gauge ports) are machine finish only. They cannot be polished to spec without damaging the treads. For pure gas installations, Tri-clamp, or weld end connections recommended if specific surface finish is required at bottom of cavity ports.

OPTIONS

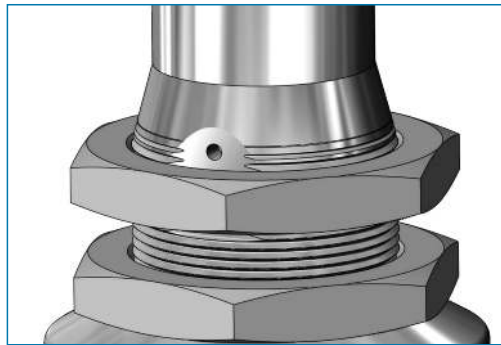

Panel Mount Option

OPTION DEFINITION

Panel Mount

The panel mount feature requires a panel cut out of 1-1/2" allowing insertion of the threaded spring housing, and a panel mount ring to secure the regulator against the panel.

Air Augment

The air augment option provides a means for air loading the valve spring housing for automated control. To enable this function a 1/8" FNPT collar is installed on the spring housing (the same one used for the captured vent option), and a Teflon seal nut is included to seal the adjusting screw threads to prevent leakage. The 1/8" FNPT port is used as the input fitting for loading with instrument air to completely automate or augment manual regulator control. An I/P transducer, or a small, self-relieving air set PRV regulator is required (ordered separately) to regulate the instrument air pressure.

FEATURES & BENEFITS

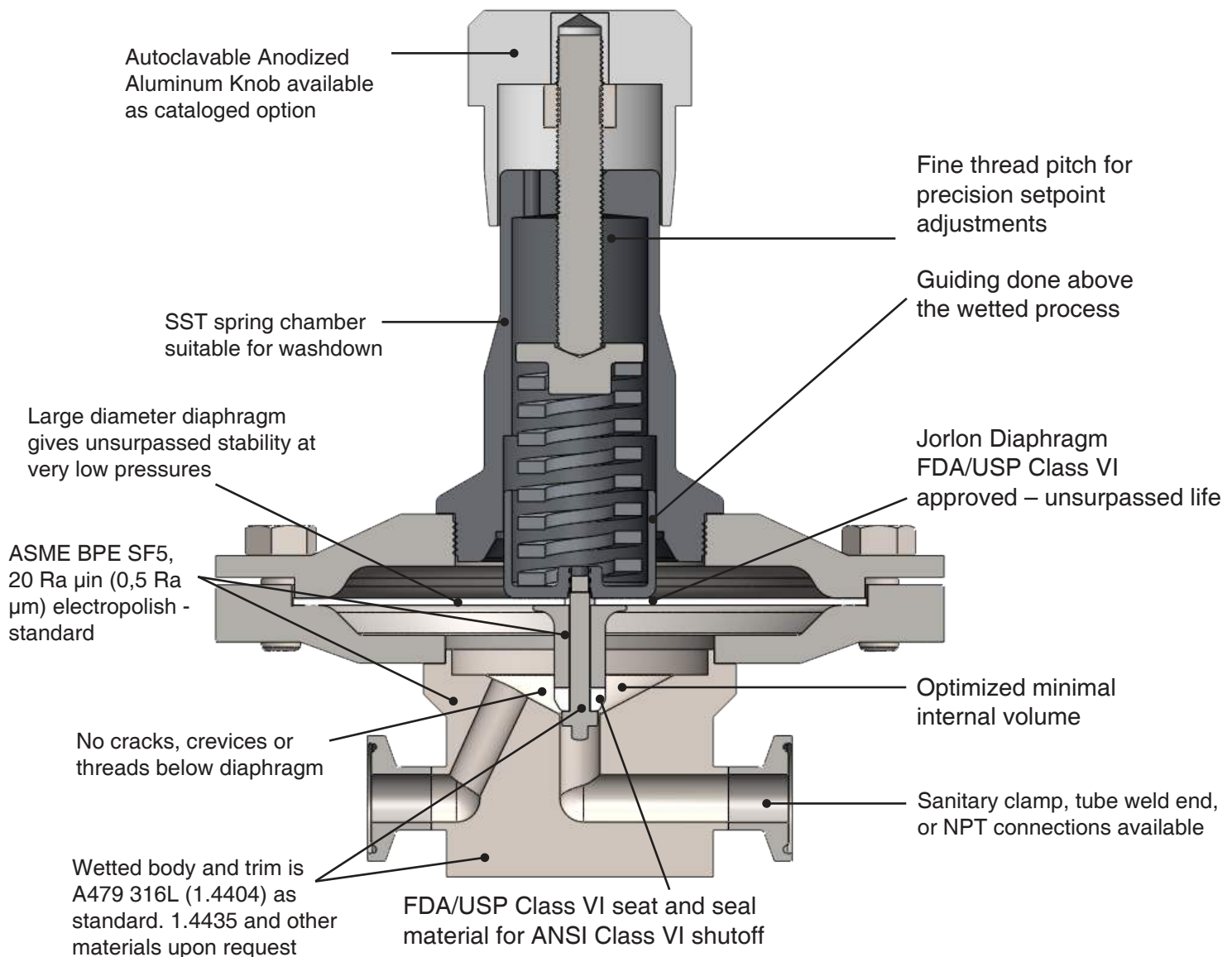

Sizing

You may use the SFCV sizing program to determine the proper Cv (Kv) trim for your application.

1. Download the SFCV program. It can be found on our website home page at www.steriflowvalve.com
2. Use the software to find the appropriate CV for your application conditions.
3. For Valve Type, select "Globe"
4. For Design Cv, input .5, or .8.
5. Input the remaining information per your application criteria, and follow the instructions at the top of the sizing page.
6. SFCV will tell you the CV needed to pass the required flow. Because the JSBLP works best under 50% capacity, you need to select a a CV for the valve that is at least two times larger than the required Cv.

Example: Clean compressed air, at ambient temperature, P1 = 45 psi, P2 = 0 psi, ½" Tri-clamp Connections, flow rate 12 scfm. Using SFCV to size for CV we find that these conditions require an actual CV of 0.37. Calculating for less than 50% capacity we then multiply the result by 2x (0.37x 2 = 0.74). This means that we should choose the 0.8 CV trim to optimize the valve for the conditions.

FLOW CONFIGURATIONS

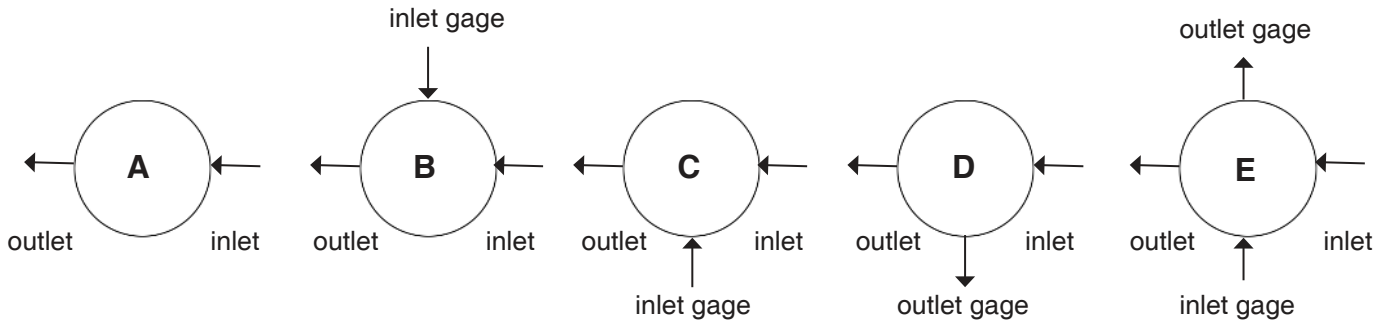

* Gage ports are 1/4" FNPT. Other porting options available at www.steriflowvalve.com under the resources tab

DIMENSIONS, IN. (MM)

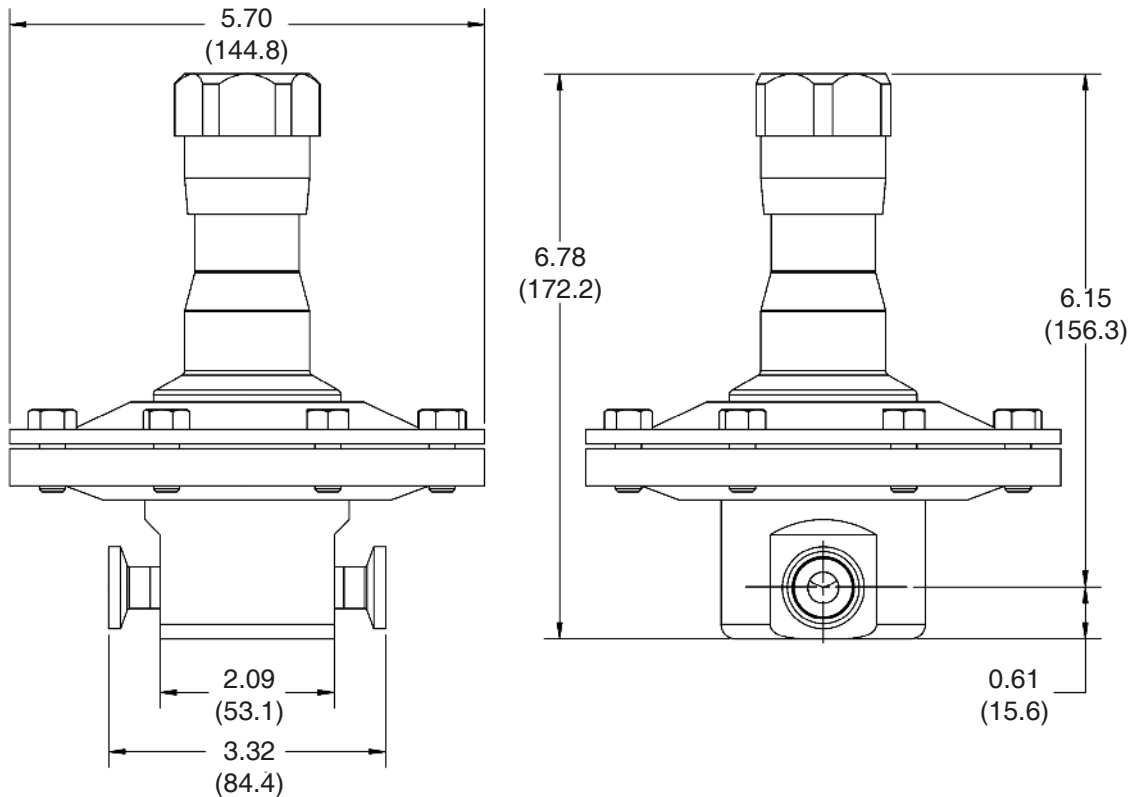

SAMPLE SPECIFICATIONS

Stainless Steel back pressure regulator shall be made from ASTM A479 316L (1.4404), or better barstock material, which includes body and all wetted metal parts, and shall have SF5, 20 Ra μin (0,5 Ra μm) electropolish finish as standard. Regulator shall be activated by an FDA approved, USP Class VI certified Jorlon diaphragm, with diameter no less than 4.5" (114,3 mm) to promote sensitivity that will accomodate set points down to 1 psig (69 mbar). Stem shall be completely guided above the wet so as not to generate metal particulate. Regulator shall be free of exposed threads and any cracks or crevices within wetted process area. Regulator shall have trim that can be replaced inline by simply unthreading the bonnet and replacing the one piece, diaphragm and trim set. Trim set must be either be Teflon, or PEEK, both FDA and USP Class VI approved.

JSBLP SERIES: COMPACT, HIGH PURITY, LOW SET POINT BACK PRESSURE REGULATOR

ORDERING SCHEMATIC

Model	Size	Material	1 & 2	3 & 4	5 & 6	7 & 8	9 & 10	11 & 12	13 & 14	15	16	17
JSBLP	50	6L										

Model	
JSBLP	High Purity Low Pressure Back Pressure Regulator

Size	
050	1/2"
075	3/4"

Material	
6L	Stainless Steel 316L
30	S. Steel 316L, ≤ 30 Ra μ in (0,76 Ra μ m) EP

1	Body Feature
End Connection	
ASME BPE Selections	
C	Tri-Clamp 20 Ra EP
P	FNPT 20 Ra EP
T	Tube Weld End 20 Ra EP
ISO Selections	
S ¹	ISO Tri-Clamp, DN15
V ¹	ISO w/34.0mm face T-Clamp, DN15
R ¹	ISO T-Clamp, DN20
H ⁴	ISO Tube Weld, DN15
DIN Selections	
D ²	DIN Tri-Clamp, DN15
N ²	DIN T-Clamp, DN15 w/50.5mm face
U ²	DIN T-Clamp, DN20
X ²	DIN T-Clamp, DN20 w/50.5mm face
M ³	DIN Tube Weld, DN15
ZZ	Non-Standard

2	Body Feature
Port Configuration*	
A	Port "A"
B	Port "B"
C	Port "C"
D	Port "D"
E	Port "E"

* Std. Gauge Ports are 1/4" FNPT. Contact factory for availability of others

9 & 10	Diaphragm Material
JL	Jorlon
ZZ	Non-Standard

11 & 12	Actuator
SK	Standard Actuator
AK	Standard Actuator / Autoclavable Anod. Aluminum Knob
PM	Panel Mount
TP	Tamper Proof
AA	Air Augment
ZZ	Non-Standard

13 & 14	Inlet Gauge*
ØB	0 - 30 PSIG/Bar (Dual)
ØC	0 - 60 PSIG/Bar (Dual)
ØD	0 - 100 PSIG/Bar (Dual)
ØE	0 - 160 PSIG/Bar (Dual)
ØF	0 - 200 PSIG/Bar (Dual)
ØN	None
ZZ	Non-Standard

* Customer assumes all responsibility for possible damage or injury if selected gauge span does not fully cover range spring / outlet pressure option

15	Outlet Gauge*
B	0 - 30 PSIG/Bar (Dual)
C	0 - 60 PSIG/Bar (Dual)
D	0 - 100 PSIG/Bar (Dual)
E	0-160 PSIG/Bar (Dual)
N	None
ZZ	Non-Standard

* Customer assumes all responsibility for possible damage or injury if selected gauge span does not fully cover range spring / outlet pressure option

16	SEP Compliance
O	None Required
G	SEP Compliant
Z	Non-Standard

17	Accessories
O	None Required
S	Clean For Oil Free
X	Clean for Oxygen*
J	Clean for Oxygen, Assemble Dry* ¹
Z	Non-Standard

*Procedure complies with ASTM G-93 2011 and CGA G-4.1-2009

¹Use of Oxygen safe lubricant (Krytox™ for example) can affect gas line particulate testing. Assembling all wetted components dry (without lubricant) removes that effect, however it may increase the difficulty in disassembly/reassembly of valve seat components during valve maintenance. Note that we will use O2 safe lubricant on non-wetted threaded components.

¹ Acc. to DIN 32676 Row B (ISO 1127). See dimensions, page 5

² Acc. to DIN 32676 Row A. See dimensions, page 5

³ Acc. to DIN 11866, DIN 11850 Row A

⁴ Acc. to DIN 11866 Row B

3 & 4	Trim
1S	0.8 Cv
2S	0.5 Cv
ZZ	Non-Standard

5 & 6	Seat Material
TF	PTFE
PK	Peek
ZZ	Non-Standard

7 & 8	Spring Range
01	1 - 15 PSI
05	5 - 15 PSI
15	15 - 25 PSI
25	25 - 50 PSI
ZZ	Non-Standard



Steriflow, a division of Jordan Valve

3170 Wasson Road • Cincinnati, OH 45209

513.533.5600 • 800.543.7311 • 513.871.0105 (f)

steriflow@richardsind.com • www.steriflowvalve.com