

JSRHF Series

**NEW: Air Augment
Option: See Page 6**

High Flow Bioprocess Clean Gas Pressure Reducing Valves

The JSRHF Series high purity gas pressure regulator was designed and built specifically for Bio-Pharma gas applications.

Traditionally, manufacturers adapted their industrial gas regulators for use in biopharm by simply changing the construction materials and surface finish. Not so with the JSRHF. It's been designed specifically to minimize the exposed threaded connections associated with those traditional designs. And, it features an in-line removable trim set to facilitate quick trim change out and cleaning without valve removal or disassembly.

The durable valve body is machined from ASTM A479 316L. The metal trim components are machined from S21800 Nitronic 60 to prevent galling. The internal components are finished to ASME BPE SF5 20Ra μm (0.5 Ra μm), electropolished standard. The valve is outfitted with the rugged Jorlon diaphragm and Teflon seats and seals that are all FDA approved, USP Class VI compliant materials. These materials of construction enable JSRHF to withstand the rigors of SIP and CIP processes (if required for valves used on liquid applications).



FEATURES

- In-line removable seat and trim facilitate cleaning and maintenance
- Barstock construction guarantees material integrity and surface finish
- Minimized internal volume
- Proprietary Jorlon diaphragm material provides exceptionally long life, CIP/SIP capability, and FDA and USP Class VI compliance
- Soft seat material for ANSI Class VI shutoff

DOCUMENTATION

- The following documentation is shipped at no charge:
- Steriflow Unicert, a QC signed Certificate of Compliance for:
 - Material, listing heat numbers with attached MTR's
 - Surface Finish
 - FDA/USP Class VI - for all thermoplastic and elastomers
 - Traceability:
 - Each individual product serial number is traceable to the Unicert serial number, heat numbers and attached MTR's

- Other documents must be requested at time of RFQ, or order:
- ADI/TSE Free, Certified Test reports, Certificate of Origin.

APPLICATIONS

Ideal for clean gases typically found in bio-pharmaceutical, pharmaceutical and food & beverage processes including:

Clean Filter Air
Nitrogen
Carbon Dioxide
Argon
Oxygen
Custom purge or blanket gas

NOTE: Though not drainable in any installation orientation, this valve can be used on clean steam or non-cavitating liquids with Steriflow engineering application approval.



Steriflow by Jordan Valve
3170 Wasson Road • Cincinnati, OH 45209
513.533.5600 • 800.543.7311 • 513.871.0105 (f)
steriflow@richardsind.com • www.steriflowvalve.com

SPECIFICATIONS

Sizes: 3/4" - 2" (DN20 - DN50)

End Connections: Tri-clamp, Tube weld end and NPT Standard. VCR® on Tri-clamp connections optional, contact factory

Gauge Ports: 1/4" FNPT is standard. Consult factory for others

Body and Trim Material*: ASME SA479 316L (UNS 31603) is standard. EN 10272:2000 GR 1.4435, AL-6XN®, Hastelloy®C-22 and others are optional.

Body Seals: Elastomer o-rings (EPDM, Viton, Silicon, Kalrez) - All FDA and USP Class VI compliant

Soft Seat: PTFE to +252°F (122°C) continuous or 275°F (135°C) intermittent [not to exceed 15 min. in a one hour period] FDA, USP Class VI

Shutoff: Class VI

Spring Range:

- 25 - 250 psi (1,7 - 17,2 bar)
- 10 - 150 psi (0,7 - 10,3 bar)
- 5 - 100 psi (0,3 - 6,9 bar)
- 5 - 50 psi (0,3 - 3,4 bar)
- 5 -20 psi (0,3 - 1,4 bar) (2.5 & 3.5 Cv only)

Sizing: Use SVCV Steriflow software sizing module, Size at 60% capacity for 2.5 & 3.5 Cv models, and size at 70% capacity on 5, 7.5 & 10 Cv models

Maximum Operating Pressure: 300 psi max inlet @ 100°F / psi max ΔP

* The return spring is manufactured from 316 steel.

** NPT treaded end valves: Threads are not 20 Ra (0.5 Ra). Bottom of outlet cavities (inlet, outlet, or gauge ports) are machine finish only. They cannot be polished to spec without damaging the treads. For pure gas installations, Tri-clamp, or weld end connections recommended if specific surface finish is required at bottom of cavity ports.

Maximum Operating Temperature: 250 psi max inlet @ 275°F

Optional Cleaning Specifications:

- Clean for Oil-Free
- O2 Cleaning complying with ASTM G93-03 2011 and CGA G-4.1-2009

Flow Capacity - Cv (Kv)

- 3/4": Cv 2.5 (Kv 2,16)
- 1" & 1-1/2": Cv 3.5 (Kv 3,03), Cv 5 (Kv 4,31), Cv 7.5 (Kv 6,47), Cv 10 (Kv 8,65)
- 2": Cv 5 (Kv 4,31), Cv 7.5 (Kv 6,47), Cv 10 (Kv 8,65)

Failure - Cv (Kv)

Valve Cv	Failure Cv
2.5	3 (Kv 2,59)
3.5	4.2 ((Kv 3,63)
5	6 (Kv 5,18)
7.5	9 (Kv 7,78)
10	12 (Kv 10,37)

Surface Finish:

- Wetted Internal surface finish: Mechanically polished, and electropolished to ASME BPE SF5, 20 Ra µin (0.5 Ra µm) as standard**
- Exterior surface finish: Mechanically polished, and electropolished to 40 Ra µin (1.0 Ra µm) as standard,
- Other finishes available upon request

Options:

- Panel Mount

Note: For a complete ancillary list of all wetted and non-wetted material specifications, please contact Steriflow Valve.

DIMENSIONS

2.5 & 3.5 Cv Model

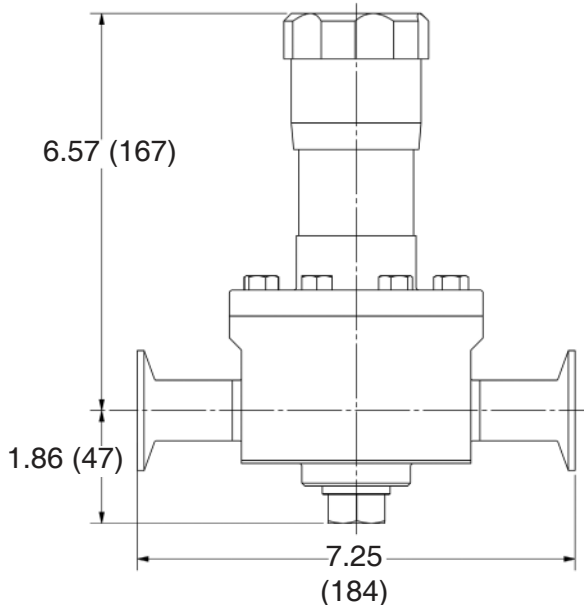

Weight: 12 lbs (5 kgs)

5, 7.5 & 10 Cv Model

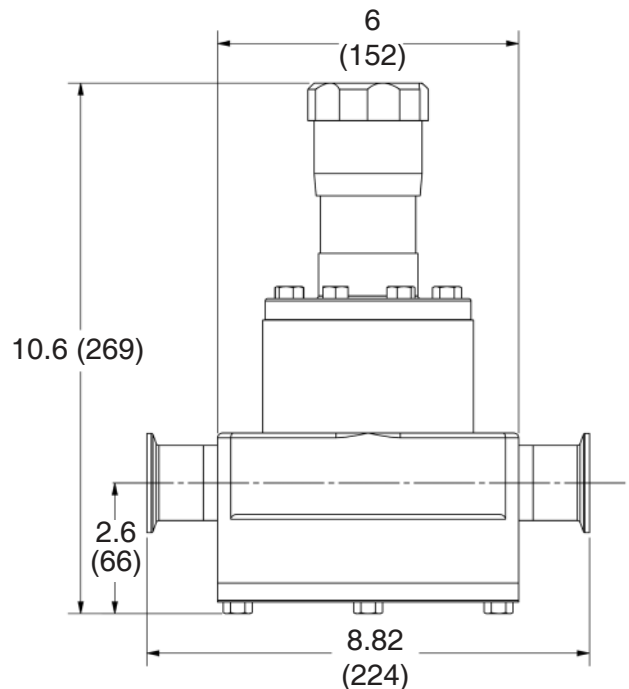

Weight: 33 lbs (15 kgs)

FEATURES & BENEFITS - MODEL JSRHF: 2.5 AND 3.5 Cv

Autoclavable anodized aluminum knob
available as cataloged option

Five different color coded spring
ranges allow you to select the
optimum spring for your application
to minimize droop

One piece diaphragm sub assembly
promotes quick, inline maintenance and
fewer spare parts

Rugged bolted spring
housing eliminates potential
bonnet compression failures
due to inline vibration

Long lived Jorlon® diaphragm
(FDA and USP <88>, and
<87> Class VI) virtually
eliminates repetitive cycle
induced diaphragm failures

All wetted parts are
ASTM A479 316L

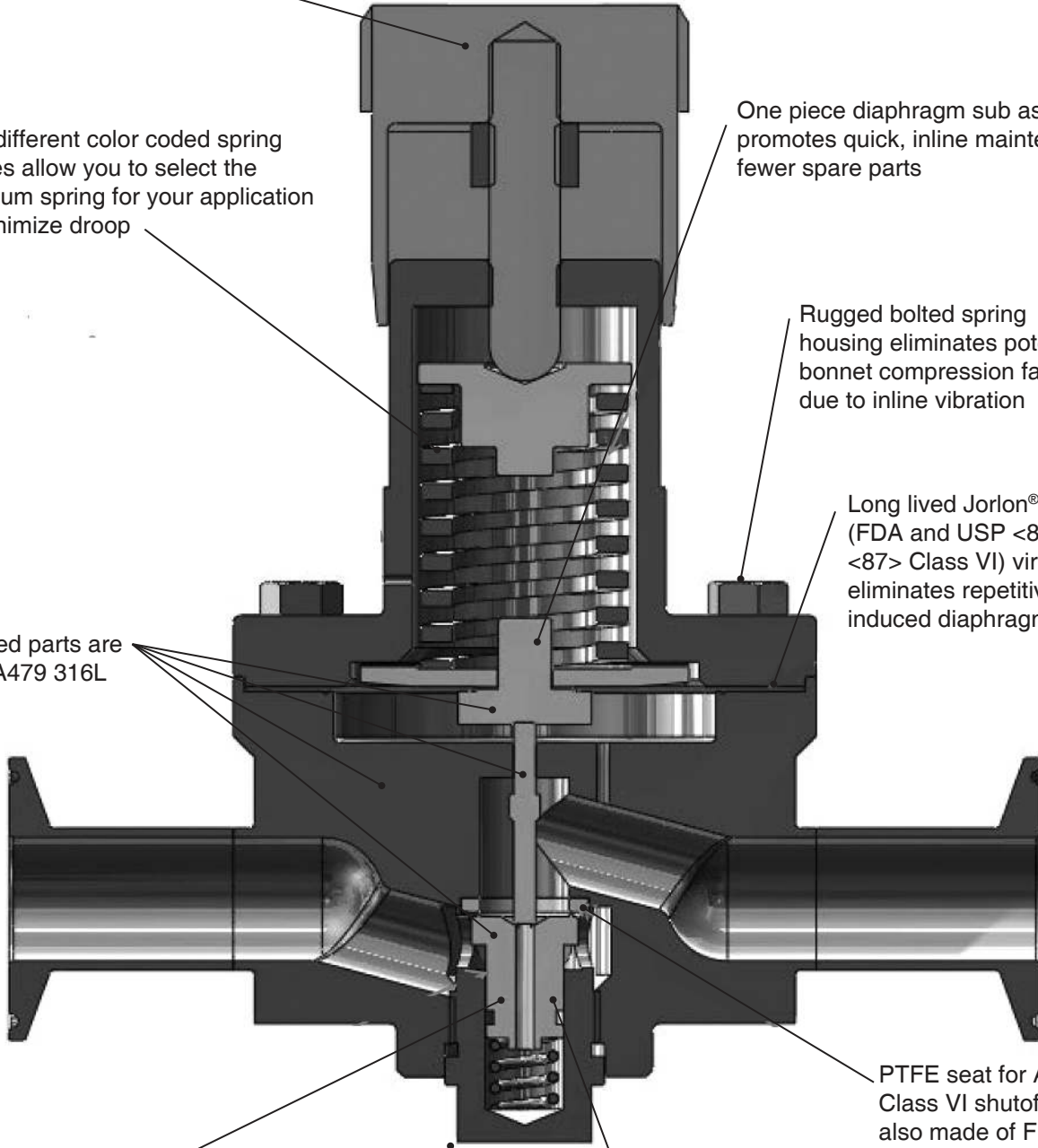

Balanced port design minimizes DP
forces on the plug, maximizing stability
in spite of supply pressure variations

In-line removable seat and plug subassembly facilitates
cleaning and maintenance in less than 10 minutes

PTFE seat for ANSI
Class VI shutoff. Seat is
also made of FDA and
USP Class VI compliant
material

NOTE: Can be used on clean steam or
non-cavitating liquids (the design is not
drainable) with Steriflow engineering ap-
plication approval.

FEATURES & BENEFITS - MODEL JSRHF: 5, 7.5 & 10 Cv

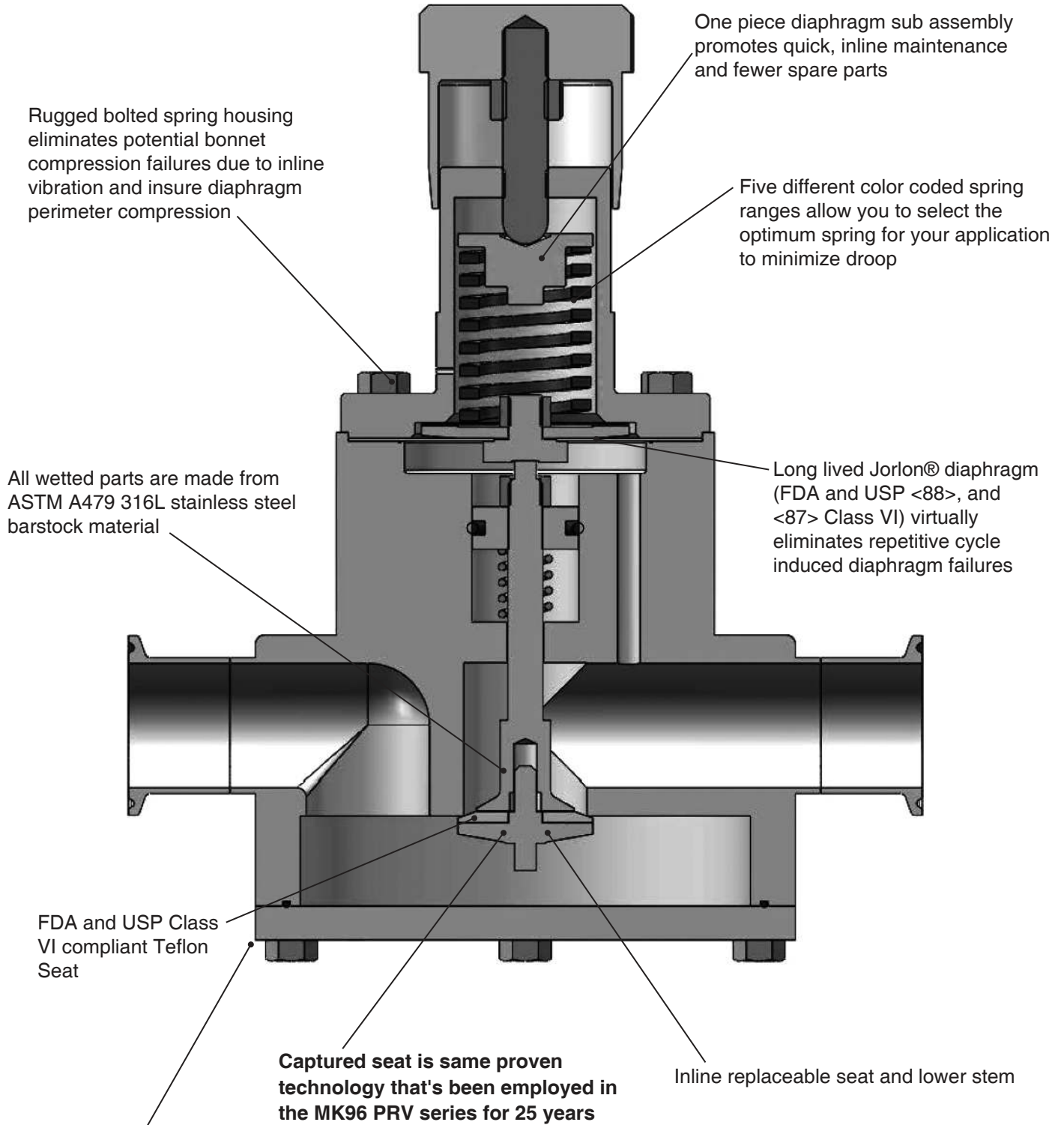

NOTE: Can be used on clean steam or non-cavitating liquids (the design is not drainable) with Steriflow engineering application approval.

PANEL MOUNT (PM) OPTION FOR JSRHF 2.5, 3.5 Cv

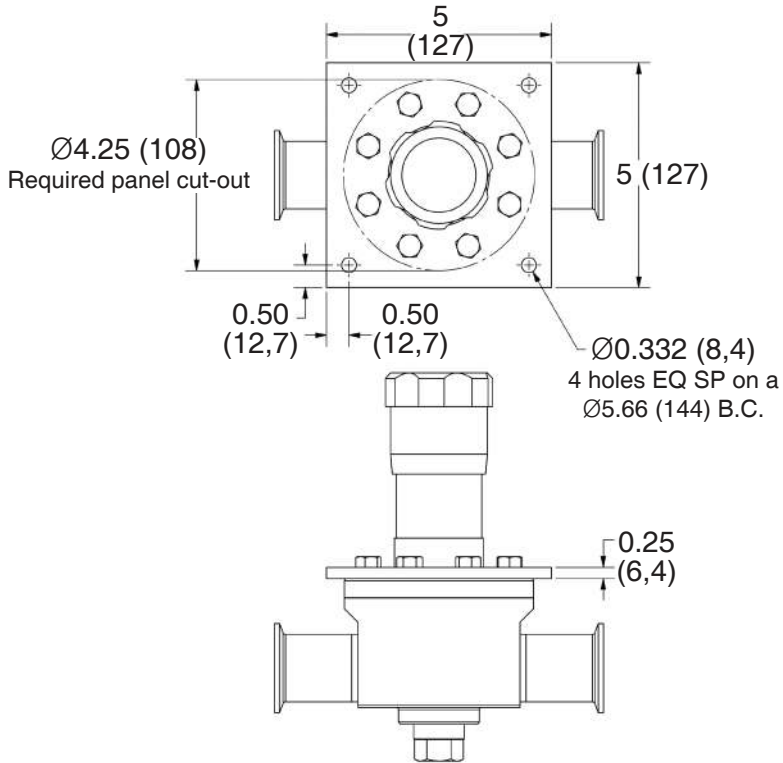

Weight: 12 lbs (5 kgs)

PANEL MOUNT (PM) OPTION FOR 5, 7.5 & 10 Cv

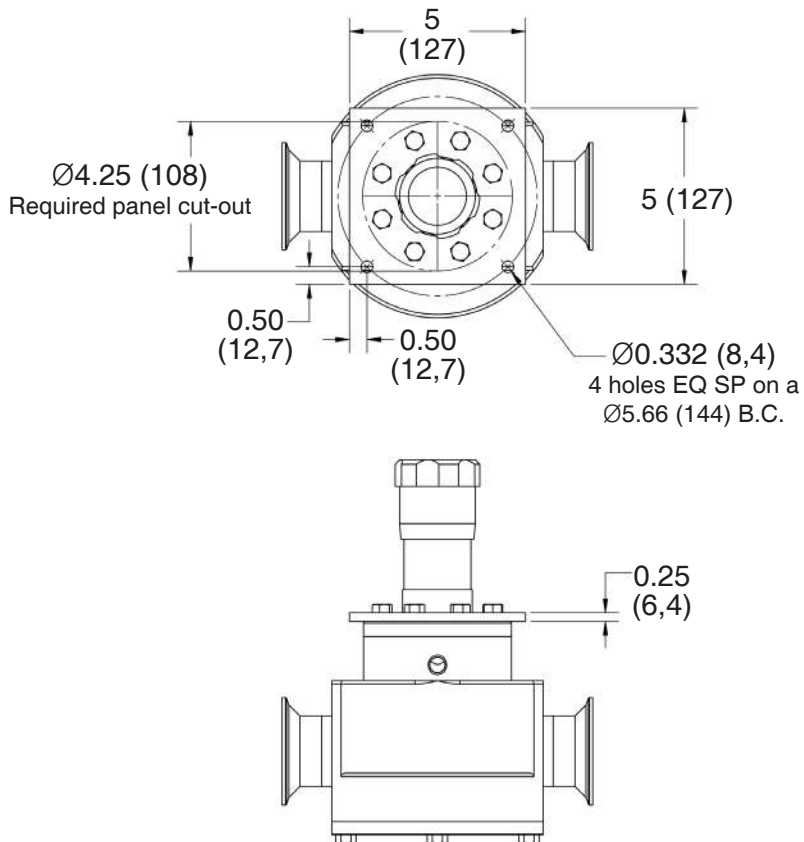

Weight: 33 lbs (15 kgs)

FLOW CONFIGURATIONS/ GAUGE PORT OPTIONS

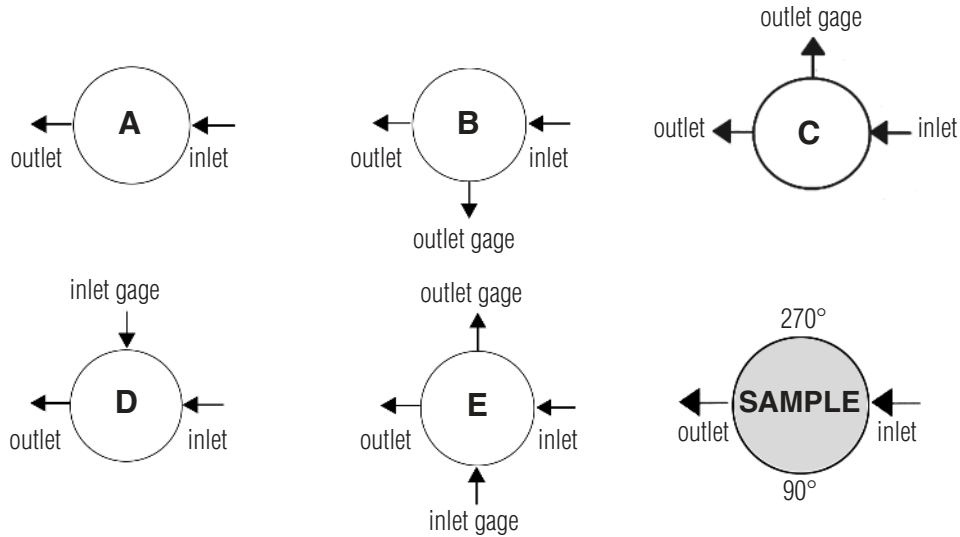

* Gauge ports are 1/4" FNPT. Consult factory for Tri-clamp, VCR or other alternatives, or porting options.

OPTIONS FOR JSRHF

Air Augment

The air augment option provides a means for air loading the valve spring housing for automated control. To enable this function a 1/8" FNPT collar is installed on the spring housing (the same one used for the captured vent option), and a Teflon seal nut is included to seal the adjusting screw threads to prevent leakage. The 1/8" FNPT port is used as the input fitting for loading the spring housing with instrument air to completely automate or augment manual regulator control. An I/P transducer, or a small, self-relieving air set PRV regulator is required (ordered separately) to regulate the instrument air pressure.

SAMPLE SPECIFICATIONS

Stainless Steel pressure regulator shall be made from ASTM A479 barstock material, which includes body and all wetted metal parts. Regulator shall be activated by an un-tied, FDA approved, USP Class VI certified Jorlon™ diaphragm. Regulator internal to hold minimal media volume. Regulator shall have one piece diaphragm subassembly, and trim that can be replaced inline without dome/spring chamber disassembly.

ORDERING SCHEMATIC

Model	Size	Material / Connection Type	Opt. Finish	1 & 2	3 & 4	5 & 6	7 & 8	9 & 10	11 & 12	13 & 14	15	16	17
JSRHF	075	6C	30										

Model	
JSRHF	High Flow Gas Pressure Reducing Valve

Size	
075	3/4" (DN20)
100	1" (DN25)
150	1-1/2" (DN40)
200	2" (DN50)

Material / Connection Type*	
6C	316L / Tri-Clamp
6N	316L / NPT
6T	316L / Tube Weld

* See Page 2 for complete material descriptions.

Optional Finish	
30	≤30 Ra μin (0,76 Ra μm)
blank	Leave blank for standard 20 Ra*

*NPT treaded end valves: Threads are not 20 Ra (0.5 Ra). Bottom of outlet cavities (inlet, outlet, or gauge ports) are machine finish only. They cannot be polished to spec without damaging the treads. For pure gas installations, Tri-clamp, or weld end connections recommended if specific surface finish is required at bottom of cavity ports.

1 & 2 Body Feature			
Cv / Connection Size		Port Configuration*	
A	2.5 Cv (3/4")	A	Port "A"
B	3.5 Cv (1" - 1-1/2")	B	Port "B"
C	5 Cv (1" - 2")	C	Port "C"
D	7.5 Cv (1" - 2")	D	Port "D"
E	10 Cv (1" - 2")	E	Port "E"
ZZ	Non-Standard		

* Std. Gauge Ports are 1/4" FNPT. Contact factory for availability of others.

3 & 4 O-Ring - FDA & USP Class VI	
1E	EPDM (2.5 & 3.5 Cv)
1V	Viton (2.5 & 3.5 Cv)
1K	KLRZ (2.5 & 3.5 Cv)
1L	Silicone (2.5 & 3.5 Cv)
2E	EPDM (5-10 Cv)
2V	Viton (5-10 Cv)
2K	KLRZ (5-10 Cv)
2L	Silicone (5-10 Cv)

5 & 6 Trim/Seat Material - FDA & USP Class VI	
T1	6L/PTFE (2.5 & 3.5 Cv)
T2	6L/PTFE (5 Cv)
T3	6L/PTFE (7.5 Cv)
T4	6L/PTFE (10 Cv)
ZZ	Non-Standard

7 & 8 Range Spring/Outlet Pressure	
02	5 - 20 PSI (0,3 - 1,4 bar) (2.5 & 3.5 Cv only)
05	5 - 50 PSI (0,3 - 3,4 bar)
10	5 - 100 PSI (0,3 - 6,9 bar)
15	10 - 150 (0,7 - 10,3 bar)
25	25 - 250 (1,7- 17,2 bar)

9 & 10 Diaphragm Material	
J1	Jorlon PTFE - FDA & USP Class VI (2.5 & 3.5 Cv)
J2	Jorlon PTFE - FDA & USP Class VI (5 -10 Cv)
ZZ	Non-Standard

11 & 12 Actuator	
SK	Standard Actuator / Nylon Knob
AK	Standard Actuator / Autoclavable Anod. Aluminum Knob
AA ¹	Air Loading provides fitting for air input on spring housing, and a stem seat nut
PM	Panel Mount
ZZ	Non-Standard

¹ See page 6 for complete description

13 & 14 Inlet Gauge*	
ØN	None
ØB	0 - 30 PSIG/Bar (Dual)
ØC	0 - 60 PSIG/Bar (Dual)
ØD	0 - 100 PSIG/Bar (Dual)
ØE	0 - 160 PSIG/Bar (Dual)
ØF	0 - 200 PSIG/Bar (Dual)
ØG	0 - 400 PSIG/Bar (Dual)
ZZ	Non-Standard

* Gauges are Oil Free and O2 clean as standard.

Continued on next page

ORDERING SCHEMATIC (CON'T)

Model	Size	Material / Connection Type	Opt, Finish	1 & 2	3 & 4	5 & 6	7 & 8	9 & 10	11 & 12	13 & 14	15	16	17
JSRHF	— 075	— 6C	— 30										

15	Outlet Gauge*
N	None
B	0 - 30 PSIG/Bar (Dual)
C	0 - 60 PSIG/Bar (Dual)
D	0 - 100 PSIG/Bar (Dual)
E	0-160 PSIG/Bar (Dual)
F	0 - 200 PSIG/Bar (Dual)
G	0 - 300 PSIG/Bar (Dual)
Z	Non-Standard

* Gauges are Oil Free and O2 clean as standard.

16	SEP Compliance
O	None Required
G	SEP Compliant
F	PED/CE compliance for 1-1/2" and 2"
Z	Non-Standard

17	Accessories
O	None
S	Clean For Oil Free
X	Clean for Oxygen*
A	EN10204 3.1 Cert for Cv 2.5 -3.5 Wetted Parts
B	EN10204 3.1 Cert for Cv 5-10 Wetted Parts
Z	Non-Standard

* Procedure complies with ASTM G-93 2011 and CGA G-4.1-2009