

Mark 16 Series

Side Mounted I/P & P/P Positioners

The Mark 16 valve positioner is used to enhance the performance of pneumatic control valves. In conjunction with pneumatic or electronic controllers, positioners eliminate positioning errors, shorten positioning times, and determine the direction of movement for proper positioning of the valve control element.

Mark 16 Side Mounted Pneumatic Positioner — Converts a low input signal from a pneumatic controller into a high output pneumatic signal for improved positioning.

Mark 16-I/P Side Mounted Electro-Pneumatic Positioner — Converts an analog input signal from an electronic controller into a pneumatic output signal for positioning the control valve.



FEATURES

- Independent adjustment of stroke range and zero
- Adjustable amplification and damping
- Split ranges available
- Low vibration effect in all directions
- Travel 8 to 102 mm (0,3 to 4 in)
- Angular range 30° to 120°

SPECIFICATIONS

Mark 16 Side Mounted Pneumatic Positioner

- **Input:** 3-15 psi (0,2-1,03 bar); Split ranges also available
- **Air Supply Pressure:** 20 to 50 psig (max) (1,4 to 3,4 bar)
- **Output:** 0-100% supply pressure
- **Operating Temperature Limits:** -40°F to +180°F (-40°C to +82°C)
- **Air Consumption @ 20 psi:** 0.12 scfm (@ 1,4 bar: 0.0003N/m³)
- **Repeatability:** better than 1%
- **Connections:** 1/4" FNPT
- Includes external gauge block with gauges
- **Options:** built-in gauges; limit switch assembly; electrical position transmitter; volume booster
- **Dimensions/Weight:** approximately 4.1" x 4.1" x 2.3" (104,1mm x 104,1mm x 58,4mm); positioner only; Weight: 3 pounds (1,4 Kg)



Jordan Valve, a division of Richards Industries
 3170 Wasson Road • Cincinnati, OH 45209
 513.533.5600 • 800.543.7311 • 513.871.0105 (f)
jordan@richardsind.com • www.jordanvalve.com

SPECIFICATIONS (CONT'D)

DIMENSIONS & CONNECTIONS

Mark 16 Electro-Pneumatic Positioner

- **Input:** 0-20 mA or 4-20 mA
- **Air Supply Pressure:** 20 to 50 psig (max) (1,4 to 3,4 bar), or as limited by actuator
- **Output:** 0-100% supply pressure
- **Operating Temperature Limits:** -40°F to +180°F (-40°C to +82°C)
- **Air Consumption (@20 psi):** 0.12 scfm; (@ 1,4 bar: 0.0003N/m3)
- **Repeatability:** better than 1%
- **Connections:** 1/4" FNPT
- Includes external gauge block with gauges
- **Intrinsically safe:** Class I, Div. I, Groups A, B, C, D hazardous locations. Approved by FM and CSA
- **Options:** built-in gauges; limit switch assembly; electrical position transmitter; volume booster
- **Dimensions/Weight:** approximately 4.1" x 4.1" x 2.3" (104,1mm x 104,1mm x 58,4mm); positioner only; Weight: 3 pounds (1,4 Kg)

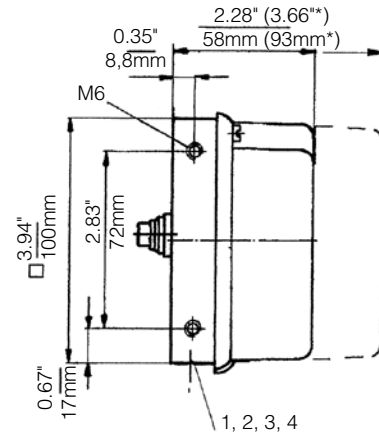
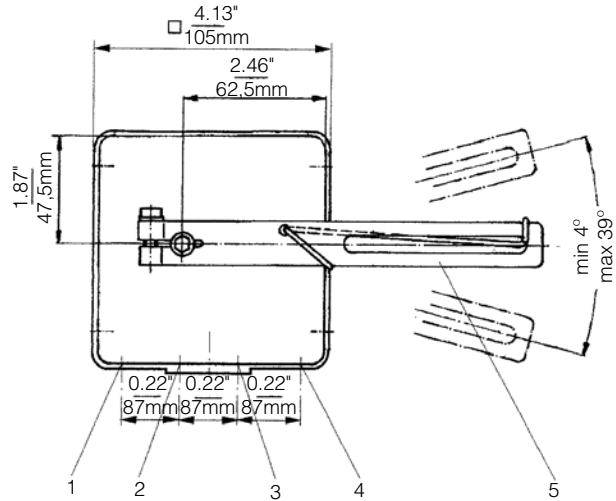

Front View

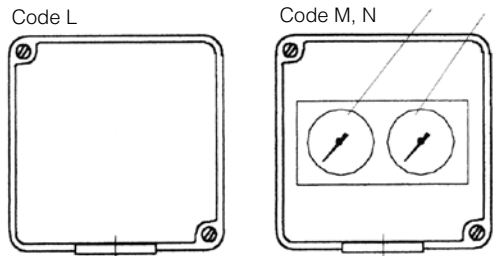

1. Female thread G 1/8 for output II (y2) (Only on double-acting positioner)
 2. Female thread G 1/8 for supply air
 3. Female thread G 1/8 for output 1 (y1)
 4. Female thread G 1/8 for input (w)
 5. Feedback lever
 6. Gauge* for input
 7. Gauge* for output
- *with gauges (optional, only on single-acting positioner)