

Mark 50HP Series

Self-Operated Back Pressure Regulators

The Mark 50HP Sliding Gate Back Pressure Regulator is used to regulate upstream pressure at a predetermined setpoint. The spring in the Mark 50HP holds the sliding gate seats in their normally closed position.

The upstream pressure is sensed beneath the diaphragm. **(A sensing line is required on sizes: 2-1/2", 3", and 4")**. As the upstream pressure exceeds the setpoint, pressure is exerted on the diaphragm which raises the stem to modulate the disc (the movable component of the sliding gate seat set) toward the open position. As the seats open, upstream pressure will be regulated to the required setpoint. A decrease in pressure relaxes the spring and diaphragm to move the seats toward the closed position.

The MK50HP option is an elongated spring housing that features a large spring for high pressure setpoints up to 450 psi (31,03 bar).

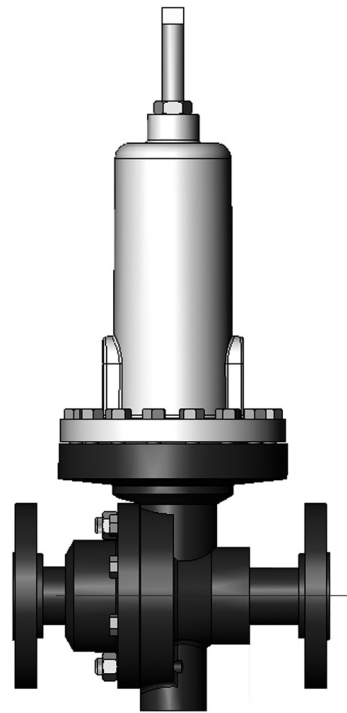

MARK 50HP FEATURES

- **Sliding Gate Trim** — unique seat design for unsurpassed trim life and accuracy.
- **Jorcote Seat Coating** — ceramic composite for liquids, gases and especially steam. Very low friction with outstanding wear resistance and a temperature rating of up to 550°F (288°C). Steam tested to 1,000,000 cycles and still maintained Class IV leakage.
- **Jorlon Diaphragm** — extremely durable, virtually universally applicable up to 450°F. Tested without failure to over 1,000,000 full stroke cycles. Ideal for steam, gases and liquids. 316SST diaphragm applicable up to 550°F.
- **Straight-through Flow** — The flow is straight through the valve seats and body. Direction of the disc travel is perpendicular to the flow, not opposed to the direction of the flow. Thus, the flow does not unbalance the seats. The MK50 can use a wider range of its stroke to give accurate control; less offset and rangeability up to 20:1.
- **Quiet Operation** — typically 5-10 dB less than conventional globe style regulators. The disc and plate are always in contact, which eliminates chattering. Straight-through flow minimizes turbulence. Multiple orifices in the plate and disc divide the flow stream into smaller flow components.
- **Minimum Maintenance** — The MK50 sliding gate seats require no special tools for disassembly. The seats are pre-lapped at the factory and are self-lapping while in operation ensuring a continual tight shutoff.



Jordan Valve, a division of Richards Industries
3170 Wasson Road • Cincinnati, OH 45209
513.533.5600 • 800.543.7311 • 513.871.0105 (f)
jordan@richardsind.com • www.jordanvalve.com

SPECIFICATIONS

Sizes: (1/4" & 3/8" sizes use 1/2" body with reducers)

- 1/4" through 4" (DN8 through DN100)

End Connections:

- Threaded – FNPT, BSPT, BSPP (1/4" – 2" only, DN8-DN50)
- ANSI Flanges (150#, 300#, 600#)
- DIN Flanges (PN10/16, PN25/40)
- JIS Flanges (upon request)

Spring Housing:

- Ductile Iron — 1/4" - 2" (DN8 - DN50)
- Ductile Iron — 2-1/2" - 4" (DN65 - DN100)

Body Materials:

- Ductile Iron
- Bronze (1/2" - 2", DN15-DN50)
- Cast Iron (2-1/2" - 4", DN65-DN100)
- Carbon Steel (A216 WCB)
- Stainless Steel (A351/CF8M)

Trim Materials:

- 303SST — Standard on Ductile Iron, Bronze, Carbon Steel valves
- 316SST — Standard on Stainless Steel valves
- Monel, Hastelloy and other Alloys available

Pressure Control Ranges: Select a range to match your setpoint. For optimal performance, your setpoint should fall in the upper portion of the selected range.

Model	Size (DN)	Spring Ranges	
		PSI	BAR
50HP	1/2" - 2" (DN15 - DN40)	75 - 190	5,17 - 13,10
		100 - 320	6,89 - 22,06
		150 - 450	10,34 - 31,02
	2-1/2" - 4" (DN65 - DN100)	25 - 50	1,72 - 3,45
40 - 130		2,76 - 8,96	

Seat Materials:

- Jorcote on SST — Standard
- Other materials available — Consult factory

Diaphragm Materials:

- Jorlon - Standard
- Stainless Steel - Standard
- Buna-N - Standard
- Viton - Optional

Service: Steam, water, oil, gas, air and chemicals

Shutoff: ANSI Class IV

Cv Values & Maximum Differential Pressures

Cv (Kv)	Size (DN)	Seat Material	Max. ΔP PSI (bar)
0.84 (0,74)	1/4" (DN8)	Jorcote	500 (34)
1.6 (1,4)	3/8" (DN12)	Jorcote	500 (34)
2.5 (2,2)	1/2" & 3/4" (DN15 & DN20)	Jorcote	450 (31)
4.4 (3,8)			
6.4 (5,5)	1" & 1-1/4" (DN25 & DN32)	Jorcote	450 (31)
9.5 (8,2)			
15 (12,9)	1-1/2" (DN40)	Jorcote	450 (31)
25 (21,5)	2" (DN50)	Jorcote	450 (31)
30 (25,8)			
55 (47,3)	2-1/2" (DN65)	Jorcote	150 (10)
115 (99)	3" (DN75)	Jorcote	150 (10)
200 (172)	4" (DN100)	Jorcote	150 (10)

Low Flow Cv's: reduced Cv's (Kv's) are available. Cv (Kv) ratings of smaller valves can be supplied in larger-sized valves.

0.42 (0,36)	0.21 (0,18)	0.08 (0,07)	0.04 (0,03)	0.02 (0,02)
0.008 (0,007)	0.004 (0,003)	0.002 (0,002)	0.0008 (0,0007)	

MAXIMUM WORKING PRESSURE, PSI

Temp °F	50 HP Series (1/2" - 2")	
	CS Body	SS Body
	600# Flange or NPT	600# Flange or NPT
100	1480	1440
200	1355	1240
300	1315	1120
400	1270	1030
500	1208	955
600	1095	905
650	1075	890

MAXIMUM WORKING PRESSURE, BAR

Temp °C	50 HP Series (DN15 - DN50)	
	CS Body	SS Body
	600# Flange or NPT	600# Flange or NPT
38	102	99
93	93	85
149	91	77
204	88	71
260	83	66
316	75	62
343	74	61

Notes:

1. 2.5" - 4" (DN65 - DN100) MK50HP, CS & SS Body, 300# Flange or NPT ends: Max Working Pressure 500 psi (34.5 bar) @ 100°F (38°C), 300 psi @ 450°F (232°C) Max.

DIMENSIONS

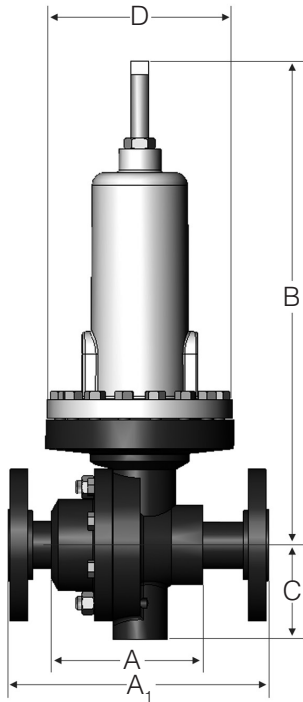

• Mark 50HP: Flanged Ends

Size	Flange	Dimensions (inches)					Weight (lbs.)
		A1		B†	C	D	
		DI/BRZ	CS/SS	All	All	All	
1/2"	150#	7.25	7.25	12.75	1.69	5.20	21
	300#	7.50	7.50	12.75	1.69	5.20	
	600#‡	8.00	8.00	12.25	1.69	5.20	
3/4"	150#	7.25	7.25	12.75	1.69	5.20	22
	300#	7.62	7.62	12.75	1.69	5.20	
	600#‡	8.12	8.12	12.25	1.69	5.20	
1"	150#	7.25	7.25	13.25	2.62	5.20	37
	300#	7.75	7.75	13.25	2.62	5.20	
	600#‡	8.25	8.25	12.75	2.62	5.20	
1-1/4"	150#	7.87	—	12.75	2.62	5.20	37
	300#	8.37	—	12.75	2.62	5.20	
1-1/2"	150#	8.75	8.75	13.75	2.31	5.20	45
	300#	9.25	9.25	13.75	2.31	5.20	
	600#‡	9.87	9.87	13.25	2.31	5.20	
2"	150#	10.00	10.00	14.00	2.75	5.20	49
	300#	10.50	10.50	14.00	2.75	5.20	
	600#‡	11.25	11.25	13.50	2.75	5.20	

† For IFE, add 1" (25,4mm) to all "B" dimensions.

‡ 600# are not IFE

• Mark 50HP: Threaded & FSW Ends

Size	Mat'l	Dimensions (inches)				Weight (lbs.)
		A	B	C	D	
1/2" & 3/4"	DI/BRZ	3.62	12.75	1.75	5.12	15
	CS/SS	3.62	12.75	1.75	5.12	17
1"	DI/BRZ	4.12	13.00	2.12	5.20	21
	CS/SS	4.18	13.25	2.12	5.20	25
1-1/4"	DI/BRZ	4.12	13.00	2.12	5.20	21
1-1/2"	DI/BRZ	4.50	13.25	2.31	5.20	23
	CS/SS	4.81	13.75	2.50	5.20	31
2"	DI/BRZ	4.50	13.25	2.50	5.20	26
	CS/SS	5.50	14.00	2.50	5.20	35

• Mark 50HP: Threaded & FSW Ends, Metric

Size (DN)	Mat'l	Dimensions				Weight (kg)
		A	B	C	D	
15 & 20	DI/BRZ	92,0	324	44,5	130,0	6,8
	CS/SS	92,0	324	44,5	130,0	7,7
25	DI/BRZ	104,7	330	53,9	132,1	9,5
	CS/SS	106,2	337	53,9	132,1	11,3
32	DI/BRZ	104,7	330	53,9	132,1	9,5
40	DI/BRZ	114,3	337	58,7	132,1	10,4
	CS/SS	122,2	349	63,5	132,1	14,1
50	DI/BRZ	114,3	337	63,5	132,1	11,8
	CS/SS	139,7	356	63,5	132,1	15,9

• Mark 50HP: Flanged Ends, Metric³

Size (DN)	Flange PN	Dimensions (mm)					Weight (kg)
		A1		B ²	C	D	
		DI/BRZ ¹	CS/SS	All	All	All	
15	10/16	184,2	130,0	324	42,9	132,1	9,5
	25/40	184,2	130,0	324	42,9	132,1	
20	10/16	184,2	150,0	324	42,9	132,1	10,0
	25/40	184,2	150,0	324	42,9	132,1	
25	10/16	184,2	160,0	337	66,6	132,1	16,8
	25/40	184,2	160,0	337	66,6	132,1	
32	10/16	199,9	—	324	66,6	132,1	16,8
	25/40	199,9	—	324	66,6	132,1	
40	10/16	222,3	200,0	349	58,7	132,1	20,4
	25/40	222,3	200,0	349	58,7	132,1	
50	10/16	254,0	230,0	356	69,9	132,1	22,2
	25/40	254,0	230,0	356	69,9	132,1	

1. Not IFE & not per DIN3202

2. For IFE, add 25,4mm.

3. For DIN flanges above PN40, please consult factory.

4. See Page 4 for dimensions on 2-1/2" - 4" (DN65 - DN100 Mark 50HP Series

DIMENSIONS

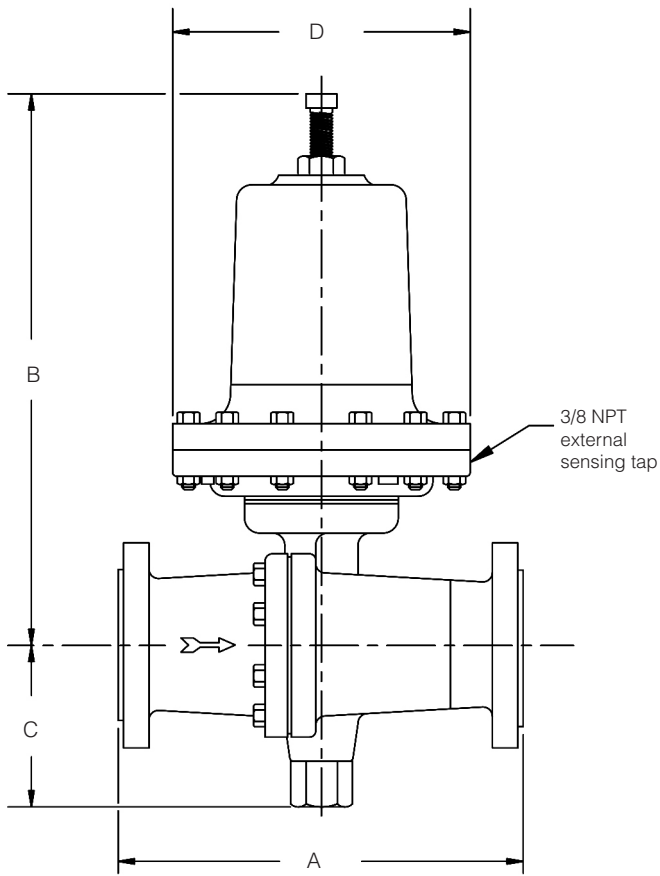

• Mark 50HP: Flanged Ends

Size	Flange Rating	Dimensions (inches)				Weight (lbs.)
		A	B	C	D	
2-1/2"	125-150#	10.88	22.25	6.95	10.65	165
	250-300#	11.50				
3"	125-150#	11.75	22.25	6.95	10.65	185
	250-300#	12.50				
4"	125-150#	13.88	23.45	8.00	10.65	215
	250-300#	14.50				

• Mark 50HP: Flanged Ends, Metric

Size (DN)	Flange PN	Dimensions (mm)				Weight (kg)
		A'	B	C	D	
DN65	10/16	287	565	177	270	75
	25/40	293				
DN80	10/16	313	565	177	270	84
	25/40	313				
DN100	10/16	353	595	203	270	98
	25/40	353				

1. Not per DIN 3202

ORDERING SCHEMATIC

1	—	2	—	3	/	4	5	6	7	8	9	10
---	---	---	---	---	---	---	---	---	---	---	---	----

2	Size			
	Inches (DN)		Inches (DN)	
025	1/4" (DN8)	150	1-1/2" (DN40)	
038	3/8" (DN10)	200	2" (DN50)	
050	1/2" (DN15)	250	2-1/2" (DN65)	
075	3/4" (DN20)	300	3" (DN80)	
100	1" (DN25)	400	4" (DN100)	

3	Body Material	
DI	Ductile Iron	
BR	Bronze (1/4" - 2")	
CS	Carbon Steel	
S6	Stainless Steel	
CI	Cast Iron (2-1/2" - 4")	

4	End Connections	
	1/4" - 2"	
PT	NPT	
BT	BSPT	
BP	BSPP	
SW	FSW	
F1	125#FE (Except IFE)	
I5	150# IFE	
F5	150# FE (except IFE)	
F2	250# FE (except IFE)	
I3	300# IFE	
F3	300# FE (except IFE)	
I7	PN 10 DIN IFE (CS/S6)	
I6	PN 16 DIN IFE (CS/S6)	
I8	PN 25 DIN IFE (CS/S6)	
I4	PN 40 DIN IFE (CS/S6)	
2-1/2" - 4"		
I1	125# IFE	
I5	150# IFE	
I2	250# IFE	
I3	300# IFE	
I7	PN 10 DIN IFE (CS/S6)	
I6	PN 16 DIN IFE (CS/S6)	
I8	PN 25 DIN IFE (CS/S6)	
I4	PN 40 DIN IFE (CS/S6)	

5	Trim			
S3	303SS	I3	303SSF/IFE (1/2" - 2")	
S6	316SS	I6	316SSF/IFE (1/2" - 2")	

6	Seat Material			
A	303SST (1/4" - 2")	V	303SS/Jorcote	
B	316SST (1/4" - 2")	W	316SS/Jorcote	
Q	303SST/Teflon Coated	R	316SST/Teflon Coated	

7	Cv (Kv)			
1	0.21 (0,28)	9	15 (12,93)	
2	0.42 (0,36)	A	25 (21,55)	
3	0.84 (0,72)	B	30 (25,86)	
4	1.6 (1,38)	D*	55 (47,41)	
5	2.5 (2,16)	F*	85 (73,28)	
6	4.4 (3,79)	G*	115 (99,14)	
7	6.4 (5,52)	I*	200 (172,41)	
8	9.5 (8,19)	* 2-1/2" - 4" only		

8	MK50HP Spring Range PSI (BAR)			
		1/2" - 2"	2-1/2" - 4"	
A1	75-190 (5,17-13,10)	64	25-50 (1,72-3,45)	
A7	100-320 (6,89-22,06)	82	40-130 (2,76-8,96)	
A9	150-450 (10,34-31,02)			

9	Diaphragm	
S6	316 SST (1/4" - 2" only)	
VI	Viton	
BN	Buna-N (standard above 2"/DN50)	
JL	Jorlon	

10	Actuator	
MD	for Metal Diaphragm (1/4" - 2" only)	
ED	for Elastomer Diaphragm	

