

Mark 67 Series

Pilot-Operated Pressure Regulators

The MK67 Series is for critical pressure reducing applications and provides greater accuracy and lower offset than can be achieved with a self-operated regulator.

The MK67 regulator combines the short stroke of the sliding gate with the action of a pilot valve to create a faster, more accurate (meaning less droop as your flows increase) response. This allows for higher accuracy in a self-contained valve where control systems are not an option.

However, the primary benefit of the sliding gate seat is low total cost of ownership. This design provides unsurpassed seat and diaphragm life, ease of installation, simplified maintenance and more accurate performance.

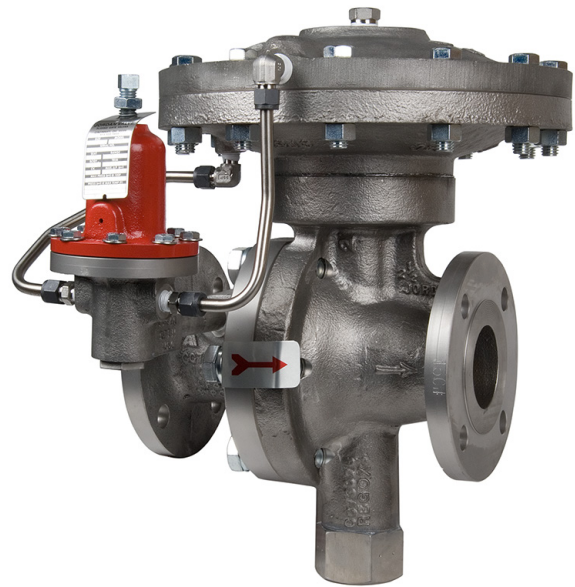

OPERATION

The Mark 67 is normally closed. The upstream pressure enters the body and passes through the piping to the pilot valve. The pilot valve is normally open, allowing the upstream pressure to act on the top of the main valve diaphragm. This force pushes the stem downward, opening the main valve. As the downstream pressure rises to the setpoint, the pilot senses the rising pressure and begins to close, which throttles the flow to the main diaphragm. The pressure on the main valve diaphragm is bled off downstream, and the main valve closes. In this way, the Mark 67 modulates between open and closed to maintain control.

Because of its versatility and accuracy, the Mark 67 can be used in a wide variety of applications including: controlling the pressure of gaseous oxygen to furnaces at steel mills, controlling pressure of sealing oil on turbines, and pressure control on steam mains and distribution lines.

FEATURES

- Mark 67 — features the Mark 69 plug-style pilot valve for pressure settings ranging from 10 psi to 200 psi (0,69 bar to 13,79 bar)
- Mark 67 with 69D Pilot — features a differential pilot for services where a constant differential must be maintained between two fluids. It is commonly used for atomizing steam and oil for combustion on oil burners where a constant differential between the steam and oil must be maintained.
- Mark 67 with 69A Pilot — features an airloaded pilot that allows remote adjustment of your pressure setpoint by changing the air pressure loaded to the dome. This option is recommended where droop must be kept to a minimum, where remote control is needed, or where frequent setpoint changes may be required.
- Sliding Gate Seats — main valve features unique seats for straight-through flow with reduced turbulence and quiet operation, fast response and tight shutoff.

SPECIFICATIONS

Line Sizes: 1/2" (DN15) through 6" (DN150)

End Connections:

- Threaded — FNPT, BSPT, BSPP (1/2" - 2" only)
- ANSI Flanges — 150#, 300#
- DIN Flanges — PN10/16, PN25/40

Body Materials:

- Ductile Iron
- Cast Iron
- Carbon Steel — A216 WCB
- Stainless Steel — A351 CF8M

Trim Materials:

- 303 SS — Standard on DI, CI or CS valves
- 316SS — Standard on SS valves

Seat Materials:

- Jorcote on SST – Standard
- Other materials available – Consult factory

Diaphragm Material: Stainless Steel

Service: steam, water, oil, gas, air and chemicals

Shutoff: ANSI Class IV

Gas Specifications: meets the requirements of General Services Administration Standard Heating Specification PB54-1530 (AM.1), Paragraph 27.4

Reduced Pressure Setpoint Ranges, PSI (BAR)

6769L		6769H & 6769D			
10-15 (0,7-1,0)	13-25 (0,9-1,7)	10-30 (0,7-2,1)	25-75 (1,7-5,2)	70-150 (4,8-10,3)	120-200 (8,3-13,8)

Operating Pressure Drops (specify when ordering)

Size	Differential Pressure Range PSI (BAR)			
1/2" - 4" (DN15-100)	15-25 (1,0-1,7)	25-150 (1,7-10,3)		
6" (DN150)	15-25 (1,0-1,7)	25-50 (1,7-3,4)	50-100 (3,4-6,9)	100-150 (6,9-10,3)

Notes:

- There is an overlap in set pressure ranges for 69L and 69H pilots. The 69H is recommended for differential pressures greater than 30 psi (2,07 bar).
- For 6" (DN150) size, four differential pressure ranges are specified. It is necessary to know which differential range applies in order to size the valve accurately.
- For service below or above the recommended differential pressure ranges or stated set pressure, consult factory,

Cv (Kv) Values

Valve Size (DN)	Max. Cv (Kv)	Valve Size (DN)	Max. Cv (Kv)
1/2" (DN15)	5.0 (4,3)	2" (DN50)	50 (43,0)
3/4" (DN20)	9.5 (8,2)	2-1/2" (DN65)	55 (47,3)
1" (DN25)	15 (12,9)	3" (DN80)	115 (98,9)
1-1/4" (DN32)	25 (21,5)	4" (DN100)	200 (172,0)
1-1/2" (DN40)	45 (38,7)	6" (DN150)	395 (339,7)

Body Pressure / Temperature Ratings

Size (DN)	Body Mat'l	End Conn.	Pressure Rating psi @ 100°F (bar @ 37,8°C)		Pressure Rating* psi/max temp °F (bar/max temp °C)	
			Std. Main Valve Bolting	Double Bolted Main Valve	Std. Main Valve Bolting	Double Bolted Main Valve
1/2" to 2" (DN15 to 50)	DI	150FE	250 (17)	250 (17)	200/400 (14/204)	200/400 (14/204)
		300FE	500 (35)	500 (35)	500/400 (35/204)	525/400 (35/204)
		TE	500 (35)	600 (41)	500/400 (35/204)	600/400 (41/204)
	CI	125FE	200 (14)	200 (14)	140/400 (10/204)	140/400 (10/204)
		250FE	500 (35)	500 (35)	290/400 (20/204)	290/400 (20/204)
		TE	500 (35)	500 (35)	290/400 (20/204)	290/400 (20/204)
	CS	150FE	285 (20)	285 (20)	125/550 (9/343)	125/550 (9/343)
		300FE	500 (35)	600 (41)	500/550 (35/343)	535/550 (37/343)
		TE	500 (35)	600 (41)	500/550 (35/343)	600/550 (41/343)
	SS	150FE	275 (19)	275 (19)	125/550 (9/343)	125/550 (9/343)
		300FE	500 (35)	600 (41)	445/550 (31/343)	445/550 (31/343)
		TE	500 (35)	600 (41)	500/550 (35/343)	600/550 (41/343)
2-1/2" to 6" (DN65 to 150)	DI	150FE	250 (17)	250 (17)	200/400 (14/204)	200/400 (14/204)
		300FE	500 (35)	500 (35)	500/400 (35/204)	500/400 (35/204)
	CI	125FE	200 (14)	200 (14)	140/400 (10/204)	140/400 (10/204)
		250FE	500 (35)	500 (35)	290/400 (20/204)	290/400 (20/204)
	CS	150FE	285 (20)	285 (20)	125/550 (9/343)	125/550 (9/343)
		300FE	500 (35)	600 (41)	500/550 (25/343)	535/550 (37/343)
	SS	150FE	275 (19)	275 (19)	125/550 (9/343)	125/550 (9/343)
		300FE	500 (35)	600 (41)	445/550 (31/343)	445/550 (31/343)

* These rating are for High Pressure Pilot, consult factory for Low Pressure Pilot (which may be lower).

MARK 67 PILOT-OPERATED PRESSURE REGULATORS

DIMENSIONS

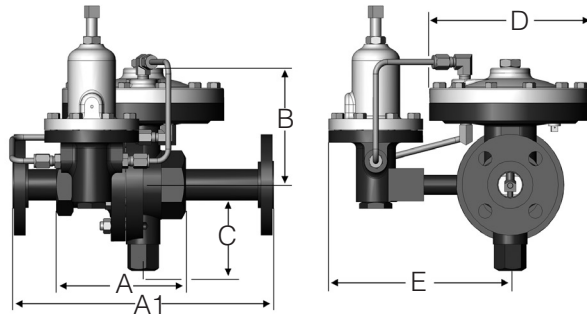

- Threaded Ends: MK6769H/L

Size	Dimension (inches)							Weight (lbs.)
	A		B	C	D	E (H)	E (L)	
	DI	CS/SS	All	All	All	All	All	
1/2"	5.31	5.5	5.06	3.5	7.12	8.0	11.5	32
3/4"	5.31	5.5	5.06	3.5	7.12	8.0	11.5	32
1"	5.69	6.5	5.25	3.62	7.12	8.0	11.5	36
1 1/4"	5.88	6.5	5.43	3.75	7.12	8.0	11.5	36
1 1/2"	8.18	8.18	7.0	5.0	10.62	9.5	13.0	37
2"	8.18	8.18	7.0	5.0	10.62	9.5	13.0	39

- Threaded Ends: MK6769H/L, DIN

Size (DN)	Dimension (mm)							Weight (kg)
	A		B	C	D	E (H)	E (L)	
	DI	CS/SS	All	All	All	All	All	
15	135	140	129	89	181	203	292	14,5
20	135	140	129	89	181	203	292	14,5
25	145	165	133	92	181	203	292	16,3
32	149	165	138	95	181	203	292	16,3
40	208	208	178	127	270	241	330	16,8
50	208	208	178	127	270	241	330	17,7

- Flanged Ends, MK6769H/L

Size	Flange	Dimensions (inches)						Weight (lbs.)
		A1	B	C	D	E (H)	E (L)	
1/2"	150#	11.5	5.06	3.5	7.12	8.0	11.5	36
	300#	11.5	5.06	3.5	7.12	8.0	11.5	36
3/4"	150#	11.5	5.06	3.5	7.12	8.0	11.5	38
	300#	11.5	5.06	3.5	7.12	8.0	11.5	38
1"	150#	11.5	5.25	3.62	7.12	8.0	11.5	42
	300#	11.5	5.25	3.62	7.12	8.0	11.5	42
1 1/4"	150#	11.5	5.43	3.75	7.12	8.0	11.5	44
	300#	11.5	5.43	3.75	7.12	8.0	11.5	44
1 1/2"	150#	14.5	7.0	5.0	10.62	9.5	13.0	49
	300#	14.5	7.0	5.0	10.62	9.5	13.0	49
2"	150#	14.5	7.0	5.0	10.62	9.5	13.0	53
	300#	14.5	7.0	5.0	10.62	9.5	13.0	53
Larger Sizes								
Size	ANSI Flange	Dimensions (inches)						Weight (lbs.)
		A1	B	C	D	E (H)	E (L)	
2 1/2"	125-150#	10.87	10.68	6.93	12.75	10.0	13.5	173
	250-300#	11.5	10.68	6.93	12.75	10.0	13.5	173
3"	125-150#	11.75	10.68	6.93	12.75	10.0	13.5	193
	250-300#	12.5	10.68	6.93	12.75	10.0	13.5	193
4"	125-150#	13.87	11.88	8.0	12.75	11.0	12.0	223
	250-300#	14.50	11.88	8.0	12.75	11.0	12.0	223
6"	125-150#	17.75	12.57	9.0	12.75	11.0	13.0	313
	250-300#	18.62	12.57	9.0	12.75	11.0	13.0	313

- Flanged Ends, MK6769H/L, DIN

Size (DN)	Flange (PN)	Dimensions (mm)						Weight (kg)
		A1	B	C	D	E (H)	E (L)	
15	10/16	292	129	89	181	203	292	16,3
	25/40	292	129	89	181	203	292	16,3
20	10/16	292	129	89	181	203	292	17,2
	25/40	292	129	89	181	203	292	17,2
25	10/16	292	133	92	181	203	292	19,0
	25/40	292	133	92	181	203	292	19,0
32	10/16	292	138	95	181	203	292	20,0
	25/40	292	138	95	181	203	292	20,0
40	10/16	368	178	127	270	241	330	22,2
	25/40	368	178	127	270	241	330	22,2
50	10/16	368	178	127	270	241	330	24,0
	25/40	368	178	127	270	241	330	24,0
Larger Sizes								
Size (DN)	Flange (PN)	Dimensions (mm)						Weight (kg)
		A1	B	C	D	E (H)	E (L)	
65	10/16	287	271	176	324	254	343	78,5
	25/40	293	271	176	324	254	343	78,5
80	10/16	313	271	176	324	254	343	87,5
	25/40	313	271	176	324	254	343	87,5
100	10/16	353	302	203	324	279	305	101,2
	25/40	353	302	203	324	279	305	101,2
150	10/16	474	319	229	324	279	330	142,0
	25/40	474	319	229	324	279	330	142,0

ORDERING SCHEMATIC

To specify a MK67 Pilot-Operated Pressure Regulator, build a model number.

1		2		3	/	4	5	6	7	8	9	10	11
----------	--	----------	--	----------	---	----------	----------	----------	----------	----------	----------	-----------	-----------

1	Model	
6769H	Standard	
6769L	Low ΔP Version	
6769D	Differential Pressure Pilot	
6769A	Air Loaded Pilot	

2	Size			
	Inches (DN)		Inches (DN)	
050	1/2" (DN15)	200	2" (DN50)	
075	3/4" (DN20)	250	2-1/2" (DN65)	
100	1" (DN25)	300	3" (DN80)	
125	1-1/4" (DN32)	400	4" (DN100)	
150	1-1/2" (DN40)	600	6" (DN150)	

3	Body Material	
DI	Ductile Iron	
CS	Carbon Steel (WCB)	
CI	Cast Iron	
S6	Stainless Steel	

4	End Connections	
1/2" - 2" Size Range		
PT	NPT	
BP	BSPT	
BP	BSPP	
SW	FSW	
F5	150#FE	
F3	300#FE	
F1	125#FE	
F2	250#FE	
2-1/2" - 6" Size Range		
I5	150#IFE CS, S6, or DI	
I3	300#IFE CS, S6, or DI	
I1	125#IFE CI	
I2	250#IFE CI	
I7	IFE PN10, all materials	
I6	IFE PN16, all materials	
I8	IFE PN25, all materials	
I4	IFE PN40, all materials	

5	Trim	
M	303SS	
S	316SS	

6	Pressure Drop		
1	15-25 (1,0-1,7)	ALL	
2	25-150 (1,7-10,3)	1/2"-4" (DN15-100)	
3	25-50 (1,7-3,4)	6" (DN150)	
4	50-100 (3,4-6,9)	6" (DN150)	
5	100-150 (6,9-10,3)	6" (DN150)	

7	Seat Material	
Q	303SST/Teflon Coated	
R	316SST/Teflon Coated	
V	303SS/Jorcote	
W	316SS/Jorcote	

8		Cv	Kv		Cv	Kv
4	1.6	1,4	V	35	30,1	
5	2.5	2,2	W	45	38,7	
6	4.4	3,78	C	50	43,0	
K	5.0	4,3	D	55	47,3	
7	6.4	5,5	G	115	98,9	
8	9.5	8,2	F	85	73,1	
9	15	12,9	I	200	172,0	
A	25	21,5	J	395	339,7	
B	30	25,8				

9	Range	
B4	10 - 15 (0,7 - 1,0) MK6769L only	
B6	13 - 25 (0,9 - 1,7) MK6769L only	
40	10 - 30 (0,7 - 2,1)	
65	25 - 75 (1,7 - 5,2)	
99	70 - 150 (4,8 - 10,3)	
A8	120 - 200 (8,3 - 13,8)	

10	Diaphragm / Actuator	
S6MD	316SST	

11	Pilot	
S3	303/SST Trim	
S6	316/SST Trim	