



HEXVALVE

Hexblok Valves

ANSI 150# up to 2500# Class and API 10K
RF or RTJ Flanges & Threaded Ends
OS&Y and Screwed Bonnet Needle Valve

HexBlok Products

Ball, Globe or Rising Stem Plug Style
Single Block, Block and Bleed and Double Block and Bleed
Flanged Instrument Isolation Valves



HexBlok Valves

Built Hex tough for a lifetime of use. See how inside . . .

HEXVALVE

A Division of
Richards Industries
3170 Wasson Road
Cincinnati, OH 45209

toll free. 800.543.7311
local. 513.533.5600
fax. 513.871.0105

www.hexvalve.com



Table of Contents

Applications	3
Specifications	4
Features	5-6
HK12 Single Flange Dimensions	7
HK22 Single Flange Dimensions	8
HK32 Single Flange Dimensions	9
HK12 Double Flange Dimensions	10
HK22 Double Flange Dimensions	11
HK32 Double Flange Dimensions	12
HK12 & HK22 NPTxNPT Hexblok - Ball Valve	13
HK32 NPTxNPT Hexblok - Ball Valve	14
Sample Quills & Injection Probes	15
Materials of Construction	16
HK12, 22, 32, 42 Ordering Schematic	17
Globe Style Valves - Specifications	18
Globe Style Valves - Features	19-20
HK10/11 Single Flange Dimensions	21
HK20/21 Single Flange Dimensions	22
HK30/31, HK40/41 Single Flange Dimensions	23
HK10/11 Double Flange Dimensions	24
HK20/21 Double Flange Dimensions	25
HK30/31, HK40/41 Double Flange Dimensions	26
NPTxNPT Hexblok - Needle Valve	27
Globe Style Valves - Materials of Construction	28
HK10, 11, 20, 21, 30, 31, 40, 41 Ordering Schematic	29
API 6A Flanged Hexbloks - Ball and Needle	30
HK10, 12, 20, 22, 30, 32, 42 Ordering Schematic	31



Hexblok Block & Bleed Valves

The Hex Valve design of pressure instrument take-off points along with sampling, injection, and drainage applications simplifies these designs by making them more compact, rigid, lighter, safer, and lower cost than the conventional piping methods.

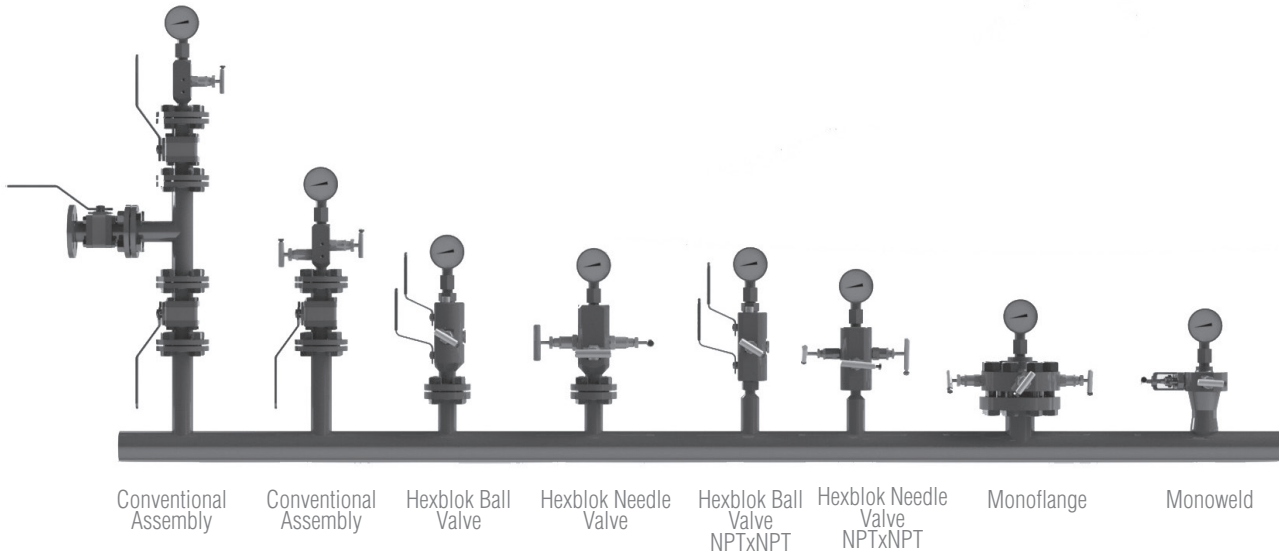

APPLICATIONS

- Pressure instrument take off points
- Sampling Systems (our valve has an integral pipe probe or sampling probe w/ optional check valve)
- Chemical Injection Systems (valve has pipe probe/quill along with optional check valve)
- Hydraulic power units
- High pressure fire safe valves
- Drains for tanks and pipes where space is limited

FEATURES & BENEFITS

- Overall length reduced by $\pm 70\%$
- Overall weight reduced by $\pm 80\%$
- Reduced labor cost
- Reduced leak points
- Brings pressure point closer to pressure measurement



Applications - Hexblok Ball Valves

HEXBLOKS are used primarily on Upstream Offshore/Onshore Oil production and initial processing installations. Typically used on liquid hydrocarbon applications to minimize the size and weight of the pipe-valve assemblies associated with gauge pressure or analytical instrumentation. Used specifically for primary and/or secondary isolation, vent and calibration access, or sampling or injection applications.

Also used in downstream Oil Refining and Petrochemical production on flanged process piping.

Specifications

WORKING PRESSURE

- In accordance to ASME B16.5 for class 150 to 2500 up to 5k

WORKING TEMPERATURES

- 450°F (232°C) for Teflon packing
- 450°F (232°C) for PEEK seals and Graphite packing (fire safe)

CERTIFICATIONS

- API 607 5th Edition (Fire Test)
- ASME VIII (pressure boundaries)
- PED
- ANSI B16.5 (flange dimensions)
- EN 10204.3.1 (material traceability)

SIZES

- 1/2" through 2"
- 10, 15, 20, & 25 mm orifice sizes

HEXBLOK ADVANTAGES & CUSTOMER BENEFITS

- 10 mm, 15mm, 20mm, and 25mm orifice/bore for lower probability of plugging
- Integral back seat on stem prevents stem blow out
- Relief slot seats and optimal seat contact curvature reduce operating torque, minimize seat wear and prevent cold flow
- Large, robust bonnet and NRT stem design on vent valve means higher probability of long life, and less break risk than competitive designs. Hex was the first in the industry to utilize Non-Rotating Stem Tip (NRT) technology. When the stem tip contacts the seat, it stops rotating, preventing the cross scoring and eventual leaks that can occur with ball type stems
- Adjustable, live loaded Teflon or Grafoil packing on ball valves insures zero external leakage
- 4 rings Teflon Chevron style packing, or multi-ring set of Grafoil surrounded by braided graphite standard on vent valve. Verified to exceed US EPA 40 CFR 60 emission standards by more than 5 times. Less probability of leaks means less risk
- Single and double flanged versions available along with NPT by NPT
- API 607 6th Edition (fire test) Standard (Graphite packed models only)
- Large variety of standard and optional forged or bar materials and outlet options, means you can select the style and material you need immediately from the catalog, instead of having to contact the factory
- Special built-to-order design inquiries welcome

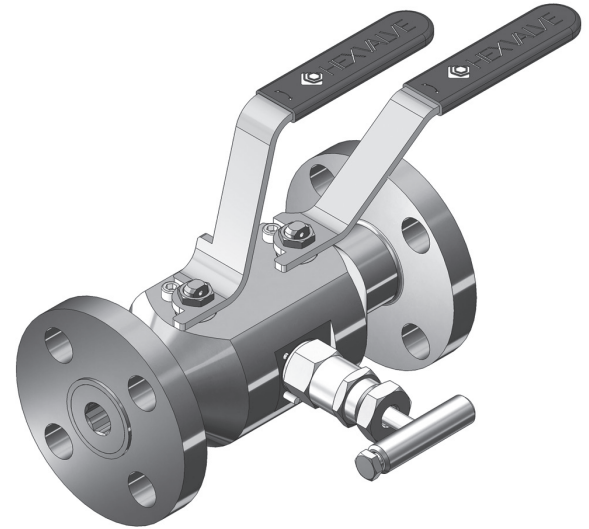

Hexblok Ball Valves

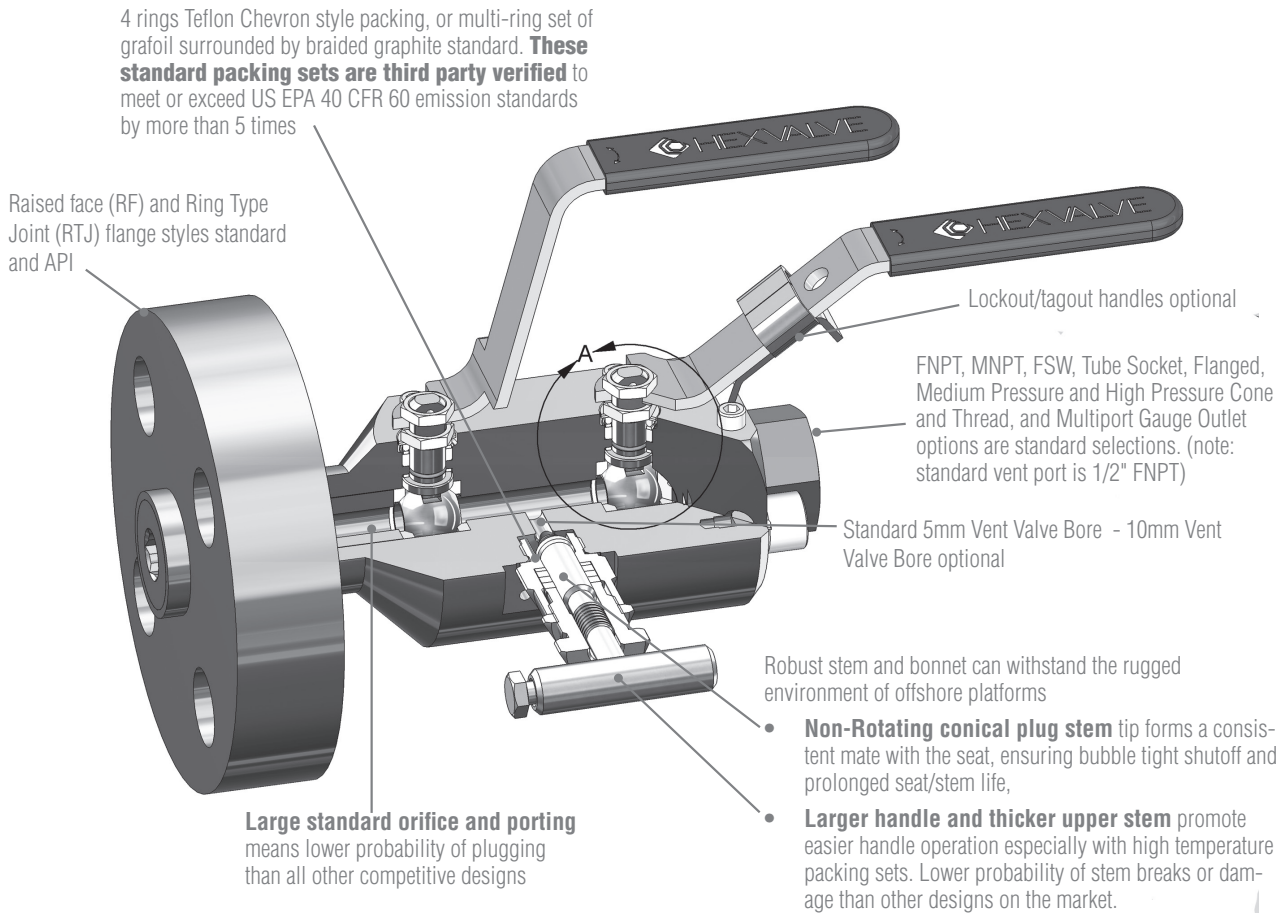

Note: Bonnet stop pin standard on screwed bonnets. Competitor's hollow spring steel pins can corrode and crack in salt water or corrosive ambient environments

- Standard materials of construction: A182F 316L (forged), Hastelloy C, Incoloy 800, Inconel 600, Low Temp CS A350 LF2 (forged), Monel 400 (forged), Carbon Steel, A105 NACE, Carbon Steel A105, A182F 316L NACE (forged), Duplex A 182 F51 (forged), Inconel (625), Super Duplex A182F55 (forged)

1/2" - 14 NPT, FNPT vent port standard

Flow Schematics

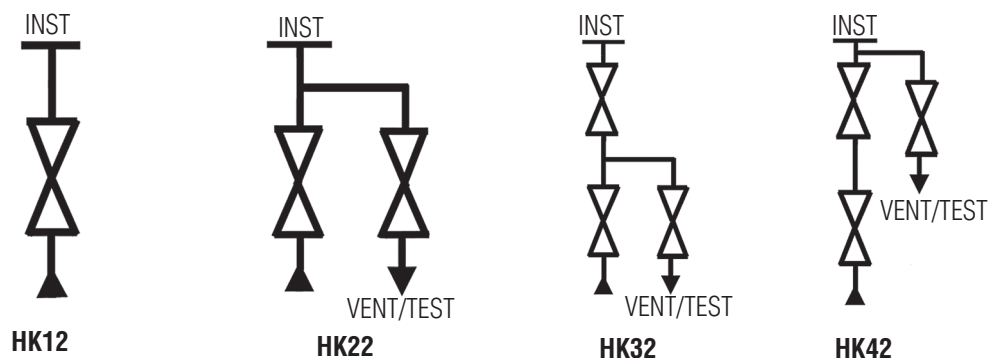



Hexblok Ball Valves

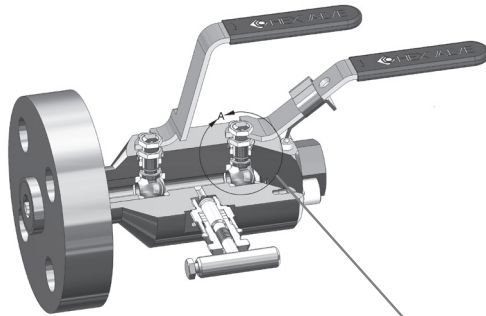

Triple stem seal (packing, o-ring, thrust washer) for improved dynamic sealing

Blowout-proof stem

Standard peek seats with triangular serrations and optimal seat contact curvature reduce operating torque, minimize seat wear, and prevent cold flow on the 10mm and 15mm Hexbloks. The larger 20mm and 25mm Hexbloks utilize a flex-seat design and optimal contact curvature to reduce operating torque, minimize seat wear, and prevent cold flow

Adjustable, live loaded Teflon-rings or Grafoil packing

Viton® O-Ring Standard

Bi-directional flow capability

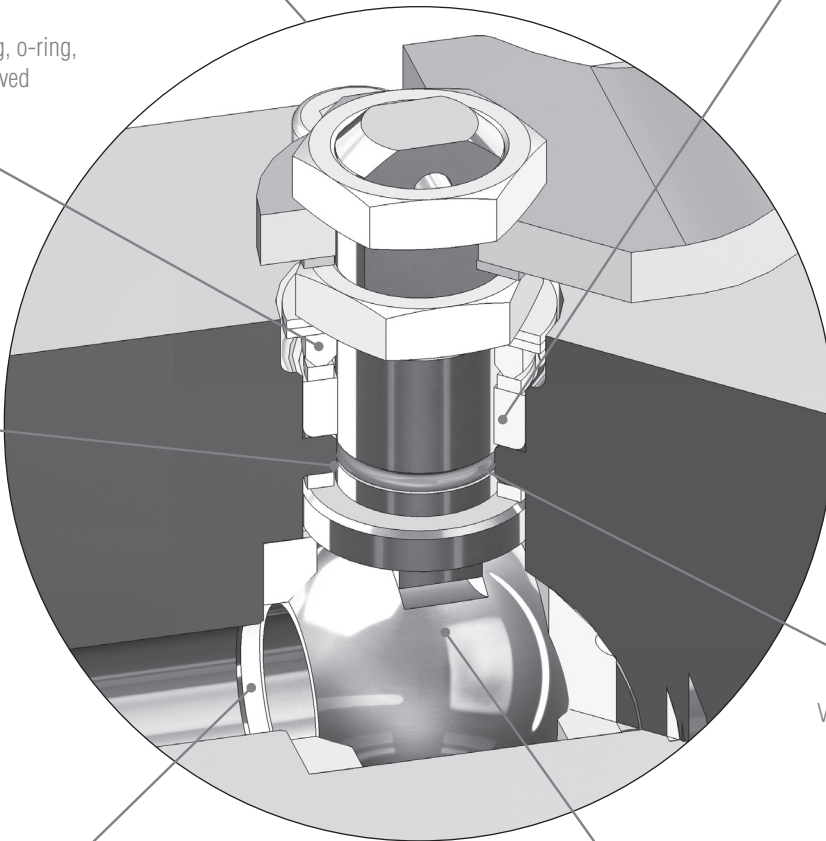



10mm Hexblok Ball Valve Dimensions & Weights - HK12 Single Flange

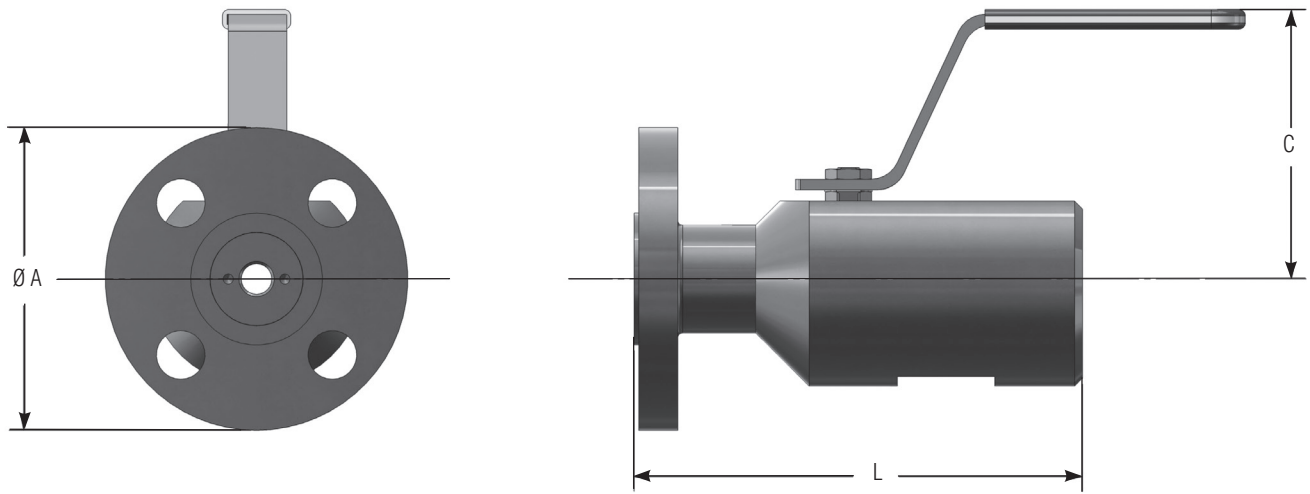

Flange Size	B16.34 Pressure Class	HK12 RF Single Flange (10mm)				HK12 RTJ Single Flange (10mm)			
		A	C	L	Weight	A	C	L	Weight
1/2"	150	3.50	2.8	7.0	10	N/A	N/A	N/A	N/A
1/2"	300	3.75	2.8	7.1	11	N/A	N/A	N/A	N/A
1/2"	600	3.75	2.8	7.3	11	N/A	N/A	N/A	N/A
1/2"	900/1500	4.75	2.8	7.7	13	N/A	N/A	N/A	N/A
1/2"	2500	5.25	2.8	8.0	16	5.25	2.8	8.0	16
3/4"	150	3.88	2.8	7.0	11	N/A	N/A	N/A	N/A
3/4"	300	4.62	2.8	7.1	12	4.62	2.8	7.3	13
3/4"	600	4.62	2.8	7.4	12	4.62	2.8	7.4	13
3/4"	900/1500	5.12	2.8	7.8	15	5.12	2.8	7.8	15
3/4"	2500	5.50	2.8	8.0	17	5.50	2.8	8.0	18
1"	150	4.25	2.8	7.1	11	4.25	2.8	7.3	12
1"	300	4.88	2.8	7.2	12	4.88	2.8	7.4	12
1"	600	4.88	2.8	7.5	13	4.88	2.8	7.5	13
1"	900/1500	5.88	2.8	7.9	17	5.88	2.8	7.9	18
1"	2500	6.25	2.8	8.2	21	6.25	2.8	8.2	21
1-1/2"	150	5.00	2.8	7.2	13	5.00	2.8	7.4	13
1-1/2"	300	6.12	2.8	7.3	15	6.12	2.8	7.5	16
1-1/2"	600	6.12	2.8	7.7	17	6.12	2.8	7.7	17
1-1/2"	900/1500	7.00	2.8	8.0	22	7.00	2.8	8.0	23
1-1/2"	2500	8.00	2.8	8.5	33	8.00	2.8	8.6	33
2"	150	6.00	2.8	7.3	15	6.00	2.8	7.5	15
2"	300	6.50	2.8	7.4	17	6.50	2.8	7.6	17
2"	600	6.50	2.8	7.8	19	6.50	2.8	7.8	19
2"	900/1500	8.50	2.8	8.3	32	8.50	2.8	8.3	33
2"	2500	9.25	2.8	8.8	45	9.25	2.8	8.8	45

10mm Hexblok Ball Valve Dimensions & Weights - HK22 Single Flange

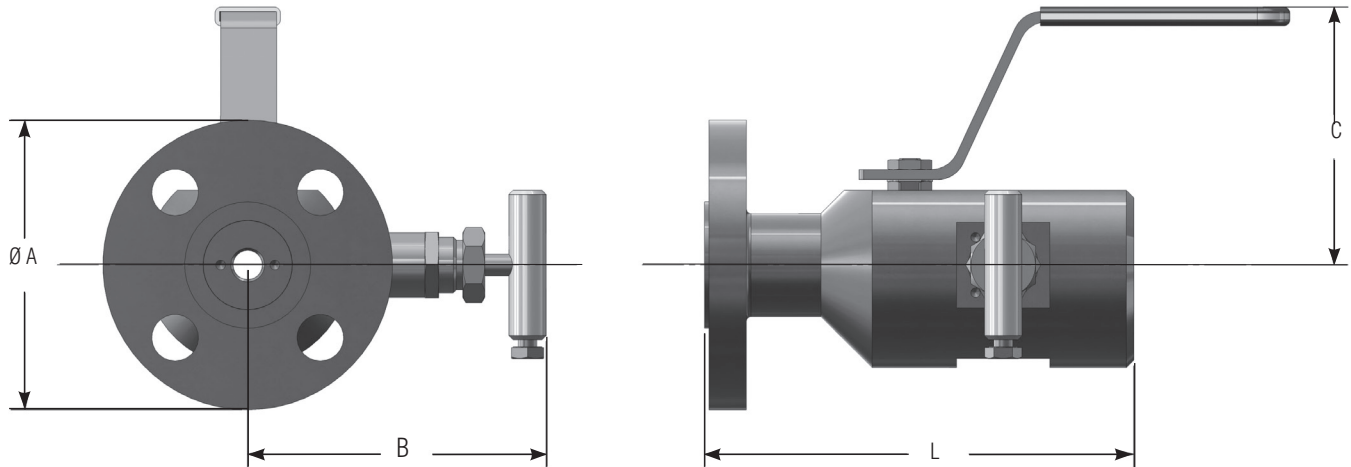

Flange Size	B16.34 Pressure Class	HK22 RF Single Flange (10mm)					HK22 RTJ Single Flange (10mm)				
		A	B	C	L	Weight	A	B	C	L	Weight
1/2"	150	3.50	4.0	2.8	7.0	11	N/A	N/A	N/A	N/A	N/A
1/2"	300	3.75	4.0	2.8	7.1	11	N/A	N/A	N/A	N/A	N/A
1/2"	600	3.75	4.0	2.8	7.3	11	N/A	N/A	N/A	N/A	N/A
1/2"	900/1500	4.75	4.0	2.8	7.7	14	N/A	N/A	N/A	N/A	N/A
1/2"	2500	5.25	4.0	2.8	8.0	16	5.25	4.0	2.8	8.0	17
3/4"	150	3.88	4.0	2.8	7.0	11	N/A	N/A	N/A	N/A	N/A
3/4"	300	4.62	4.0	2.8	7.1	13	4.62	4.0	2.8	7.3	13
3/4"	600	4.62	4.0	2.8	7.4	13	4.62	4.0	2.8	7.4	13
3/4"	900/1500	5.12	4.0	2.8	7.8	15	5.12	4.0	2.8	7.8	16
3/4"	2500	5.50	4.0	2.8	8.0	18	5.50	4.0	2.8	8.0	18
1"	150	4.25	4.0	2.8	7.1	12	4.25	4.0	2.8	7.3	12
1"	300	4.88	4.0	2.8	7.2	12	4.88	4.0	2.8	7.4	13
1"	600	4.88	4.0	2.8	7.5	13	4.88	4.0	2.8	7.5	14
1"	900/1500	5.88	4.0	2.8	7.9	18	5.88	4.0	2.8	7.9	18
1"	2500	6.25	4.0	2.8	8.2	21	6.25	4.0	2.8	8.2	22
1-1/2"	150	5.00	4.0	2.8	7.2	13	5.00	4.0	2.8	7.4	14
1-1/2"	300	6.12	4.0	2.8	7.3	16	6.12	4.0	2.8	7.5	17
1-1/2"	600	6.12	4.0	2.8	7.7	17	6.12	4.0	2.8	7.7	18
1-1/2"	900/1500	7.00	4.0	2.8	8.0	23	7.00	4.0	2.8	8.0	24
1-1/2"	2500	8.00	4.0	2.8	8.5	33	8.00	4.0	2.8	8.6	35
2"	150	6.00	4.0	2.8	7.3	15	6.00	4.0	2.8	7.5	16
2"	300	6.50	4.0	2.8	7.4	17	6.50	4.0	2.8	7.6	18
2"	600	6.50	4.0	2.8	7.8	19	6.50	4.0	2.8	7.8	20
2"	900/1500	8.50	4.0	2.8	8.3	33	8.50	4.0	2.8	8.3	34
2"	2500	9.25	4.0	2.8	8.8	45	9.25	4.0	2.8	8.8	47



10mm Hexblok Ball Valve Dimensions & Weights - HK32 Single Flange

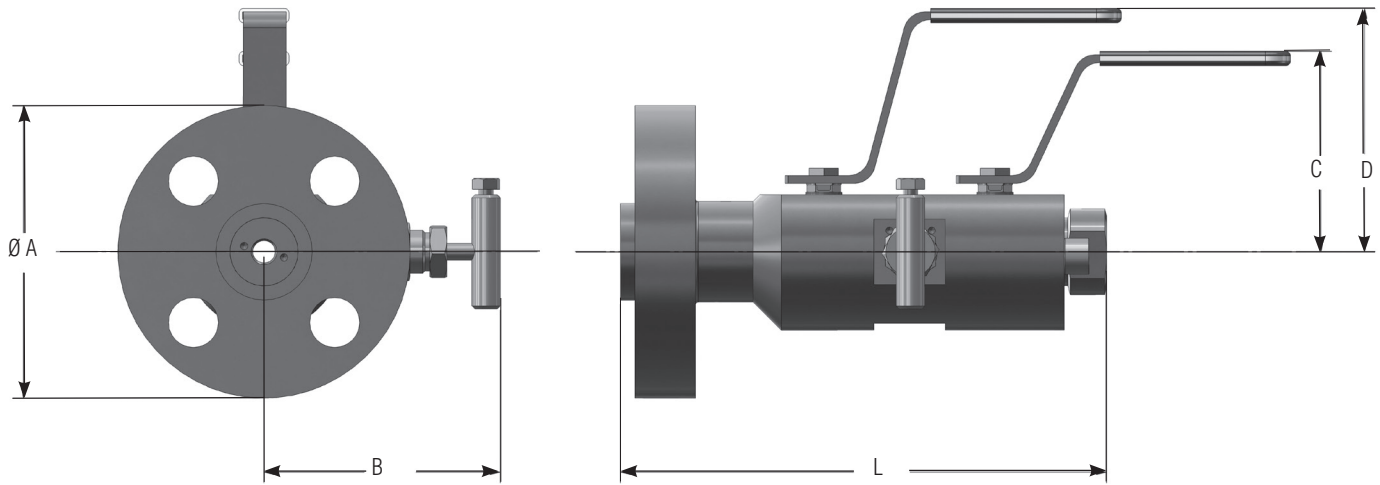

Flange Size	B16.34 Pressure Class	HK32 RF Single Flange (10mm)						HK32 RTJ Single Flange (10mm)					
		A	B	C	D	L	Weight	A	B	C	D	L	Weight
1/2"	150	3.50	4.0	2.8	4.3	6.41	11	N/A	N/A	N/A	N/A	N/A	N/A
1/2"	300	3.75	4.0	2.8	4.3	6.45	12	N/A	N/A	N/A	N/A	N/A	N/A
1/2"	600	3.75	4.0	2.8	4.3	6.45	12	N/A	N/A	N/A	N/A	N/A	N/A
1/2"	900/1500	4.75	4.0	2.8	4.3	7.27	14	N/A	N/A	N/A	N/A	N/A	N/A
1/2"	2500	5.25	4.0	2.8	4.3	7.06	17	5.25	4.0	2.8	4.3	7.06	18
3/4"	150	3.88	4.0	2.8	4.3	6.86	12	N/A	N/A	N/A	N/A	N/A	N/A
3/4"	300	4.62	4.0	2.8	4.3	6.86	13	4.62	4.0	2.8	4.3	7.05	13
3/4"	600	4.62	4.0	2.8	4.3	7.05	13	4.62	4.0	2.8	4.3	7.05	13
3/4"	900/1500	5.12	4.0	2.8	4.3	7.48	16	5.12	4.0	2.8	4.3	7.48	16
3/4"	2500	5.50	4.0	2.8	4.3	7.48	18	5.50	4.0	2.8	4.3	7.48	19
1"	150	4.25	4.0	2.8	4.3	6.53	12	4.25	4.0	2.8	4.3	6.72	113
1"	300	4.88	4.0	2.8	4.3	6.84	13	4.88	4.0	2.8	4.3	7.03	14
1"	600	4.88	4.0	2.8	4.3	7.10	14	4.88	4.0	2.8	4.3	7.10	14
1"	900/1500	5.88	4.0	2.8	4.3	7.53	18	5.88	4.0	2.8	4.3	7.53	19
1"	2500	6.25	4.0	2.8	4.3	7.79	22	6.25	4.0	2.8	4.3	7.79	22
1-1/2"	150	5.00	4.0	2.8	4.3	5.99	14	5.00	4.0	2.8	4.3	6.18	14
1-1/2"	300	6.12	4.0	2.8	4.3	6.31	16	6.12	4.0	2.8	4.3	6.34	17
1-1/2"	600	6.12	4.0	2.8	4.3	6.44	18	6.12	4.0	2.8	4.3	6.44	18
1-1/2"	900/1500	7.00	4.0	2.8	4.3	6.91	23	7.00	4.0	2.8	4.3	6.91	24
1-1/2"	2500	8.00	4.0	2.8	4.3	7.41	34	8.00	4.0	2.8	4.3	7.41	36
2"	150	6.00	4.0	2.8	4.3	6.45	16	6.00	4.0	2.8	4.3	6.64	17
2"	300	6.50	4.0	2.8	4.3	7.00	18	6.50	4.0	2.8	4.3	7.25	19
2"	600	6.50	4.0	2.8	4.3	7.04	20	6.50	4.0	2.8	4.3	7.15	21
2"	900/1500	8.50	4.0	2.8	4.3	7.54	33	8.50	4.0	2.8	4.3	7.65	35
2"	2500	9.25	4.0	2.8	4.3	8.04	46	9.25	4.0	2.8	4.3	8.15	48



10mm Hexblok Ball Valve Dimensions & Weights - HK12 Double Flange

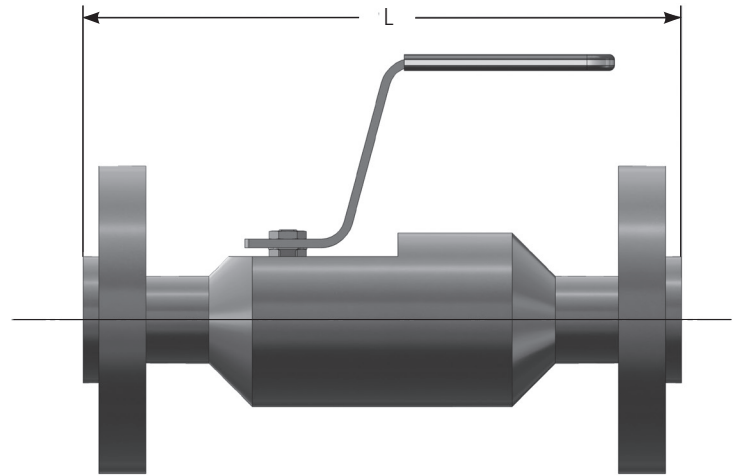
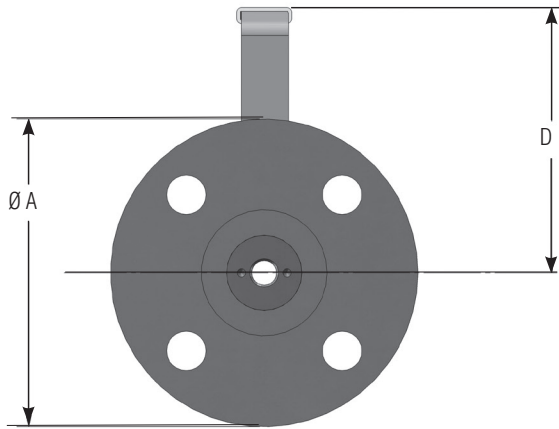

Flange Size	B16.34 Pressure Class	HK12 RF Double Flange (10mm)				HK12 RTJ Double Flange (10mm)			
		A	D	L	Weight	A	D	L	Weight
1/2"	150	3.50	4.3	8.5	12	N/A	N/A	N/A	N/A
1/2"	300	3.75	4.3	8.7	13	N/A	N/A	N/A	N/A
1/2"	600	3.75	4.3	9.2	13	N/A	N/A	N/A	N/A
1/2"	900/1500	4.75	4.3	9.9	18	N/A	N/A	N/A	N/A
1/2"	2500	5.25	4.3	10.5	23	5.25	4.3	10.5	25
3/4"	150	3.88	4.3	8.6	13	N/A	N/A	N/A	N/A
3/4"	300	4.62	4.3	8.9	16	4.62	4.3	9.2	16
3/4"	600	4.62	4.3	9.4	16	4.62	4.3	9.4	16
3/4"	900/1500	5.12	4.3	10.1	21	5.12	4.3	10.1	22
3/4"	2500	5.50	4.3	10.6	26	5.50	4.3	10.6	27
1"	150	4.25	4.3	8.7	14	4.25	4.3	9.1	15
1"	300	4.88	4.3	9.0	15	4.88	4.3	9.4	17
1"	600	4.88	4.3	9.5	17	4.88	4.3	9.5	18
1"	900/1500	5.88	4.3	10.4	26	5.88	4.3	10.4	27
1"	2500	6.25	4.3	10.9	33	6.25	4.3	10.9	34
1-1/2"	150	5.00	4.3	9.0	17	5.00	4.3	9.4	18
1-1/2"	300	6.12	4.3	9.2	22	6.12	4.3	9.6	24
1-1/2"	600	6.12	4.3	9.9	25	6.12	4.3	9.9	26
1-1/2"	900/1500	7.00	4.3	10.6	36	7.00	4.3	10.6	38
1-1/2"	2500	8.00	4.3	11.6	57	8.00	4.3	11.7	61
2"	150	6.00	4.3	9.1	21	6.00	4.3	9.5	23
2"	300	6.50	4.3	9.4	25	6.50	4.3	9.9	27
2"	600	6.50	4.3	10.1	29	6.50	4.3	10.2	31
2"	900/1500	8.50	4.3	11.1	56	8.50	4.3	11.2	59
2"	2500	9.25	4.3	12.1	81	9.25	4.3	12.2	85

10mm Hexblok Ball Valve Dimensions & Weights - HK22 Double Flange

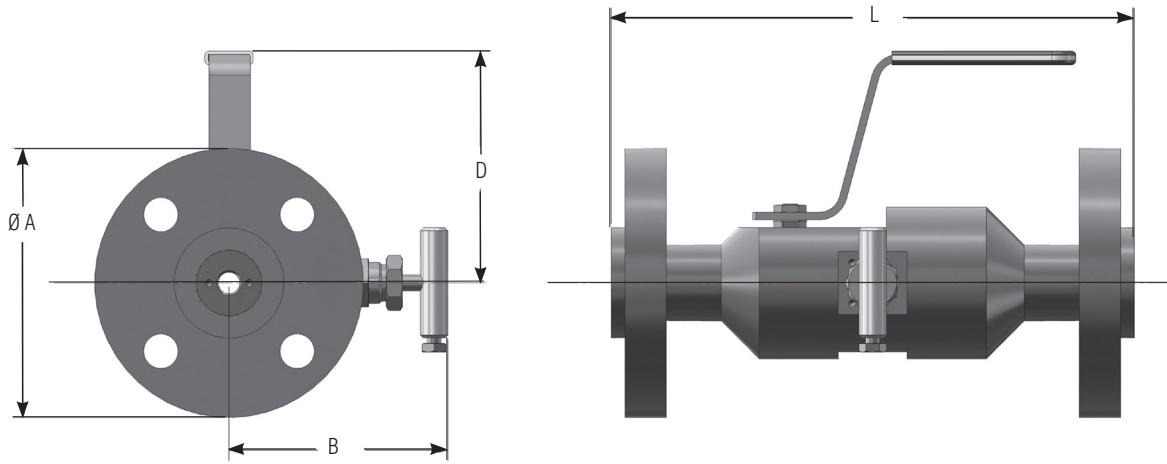

Flange Size	B16.34 Pressure Class	HK22 RF Double Flange (10mm)					HK22 RTJ Double Flange (10mm)				
		A	B	D	L	Weight	A	B	D	L	Weight
1/2"	150	3.50	4.0	4.3	8.5	12	N/A	N/A	N/A	N/A	N/A
1/2"	300	3.75	4.0	4.3	8.7	13	N/A	N/A	N/A	N/A	N/A
1/2"	600	3.75	4.0	4.3	9.2	13	N/A	N/A	N/A	N/A	N/A
1/2"	900/1500	4.75	4.0	4.3	9.9	18	N/A	N/A	N/A	N/A	N/A
1/2"	2500	5.25	4.0	4.3	10.5	23	5.25	4.0	4.3	10.5	25
3/4"	150	3.88	4.0	4.3	8.6	13	N/A	N/A	N/A	NA	NA
3/4"	300	4.62	4.0	4.3	8.9	16	4.62	4.0	4.3	9.2	16
3/4"	600	4.62	4.0	4.3	9.4	16	4.62	4.0	4.3	9.4	16
3/4"	900/1500	5.12	4.0	4.3	10.1	21	5.12	4.0	4.3	10.1	22
3/4"	2500	5.50	4.0	4.3	10.6	26	5.50	4.0	4.3	10.6	27
1"	150	4.25	4.0	4.3	8.7	14	4.25	4.0	4.3	9.1	15
1"	300	4.88	4.0	4.3	9.0	15	4.88	4.0	4.3	9.4	17
1"	600	4.88	4.0	4.3	9.5	17	4.88	4.0	4.3	9.5	18
1"	900/1500	5.88	4.0	4.3	10.4	26	5.88	4.0	4.3	10.4	27
1"	2500	6.25	4.0	4.3	10.9	33	6.25	4.0	4.3	10.9	34
1-1/2"	150	5.00	4.0	4.3	9.0	17	5.00	4.0	4.3	9.4	18
1-1/2"	300	6.12	4.0	4.3	9.2	22	6.12	4.0	4.3	9.6	24
1-1/2"	600	6.12	4.0	4.3	9.9	25	6.12	4.0	4.3	9.9	26
1-1/2"	900/1500	7.00	4.0	4.3	10.6	36	7.00	4.0	4.3	10.6	38
1-1/2"	2500	8.00	4.0	4.3	11.6	57	8.00	4.0	4.3	11.7	61
2"	150	6.00	4.0	4.3	9.1	21	6.00	4.0	4.3	9.5	23
2"	300	6.50	4.0	4.3	9.4	25	6.50	4.0	4.3	9.9	27
2"	600	6.50	4.0	4.3	10.1	29	6.50	4.0	4.3	10.2	31
2"	900/1500	8.50	4.0	4.3	11.1	56	8.50	4.0	4.3	11.2	59
2"	2500	9.25	4.0	4.3	12.1	81	9.25	4.0	4.3	12.2	85

10mm Hexblok Ball Valve Dimensions & Weights - HK32 Double Flange

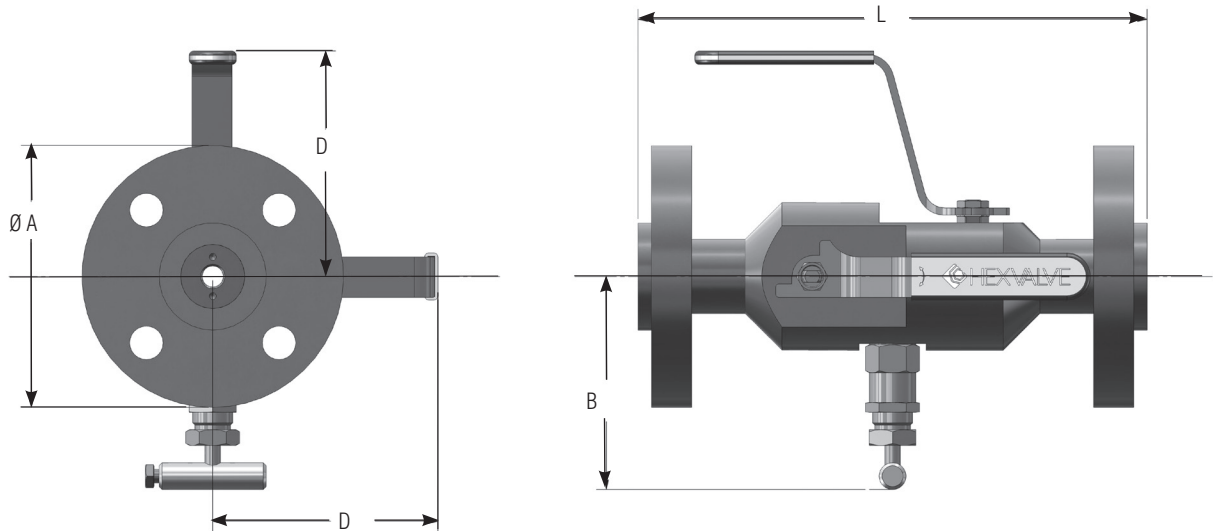

Flange Size	B16.34 Pressure Class	HK32 RF Double Flange (10mm)					HK32 RTJ Double Flange (10mm)				
		A	B	D	L	Weight	A	B	D	L	Weight
1/2"	150	3.50	4.0	4.3	8.5	12	N/A	N/A	N/A	N/A	N/A
1/2"	300	3.75	4.0	4.3	8.7	13	N/A	N/A	N/A	N/A	N/A
1/2"	600	3.75	4.0	4.3	9.2	13	N/A	N/A	N/A	N/A	N/A
1/2"	900/1500	4.75	4.0	4.3	9.9	18	N/A	N/A	N/A	N/A	N/A
1/2"	2500	5.25	4.0	4.3	10.5	23	5.25	4.0	4.3	10.5	25
3/4"	150	3.88	4.0	4.3	8.6	13	N/A	N/A	N/A	NA	NA
3/4"	300	4.62	4.0	4.3	8.9	16	4.62	4.0	4.3	9.2	16
3/4"	600	4.62	4.0	4.3	9.4	16	4.62	4.0	4.3	9.4	16
3/4"	900/1500	5.12	4.0	4.3	10.1	21	5.12	4.0	4.3	10.1	22
3/4"	2500	5.50	4.0	4.3	10.6	26	5.50	4.0	4.3	10.6	27
1"	150	4.25	4.0	4.3	8.7	14	4.25	4.0	4.3	9.1	15
1"	300	4.88	4.0	4.3	9.0	15	4.88	4.0	4.3	9.4	17
1"	600	4.88	4.0	4.3	9.5	17	4.88	4.0	4.3	9.5	18
1"	900/1500	5.88	4.0	4.3	10.4	26	5.88	4.0	4.3	10.4	27
1"	2500	6.25	4.0	4.3	10.9	33	6.25	4.0	4.3	10.9	34
1-1/2"	150	5.00	4.0	4.3	9.0	17	5.00	4.0	4.3	9.4	18
1-1/2"	300	6.12	4.0	4.3	9.2	22	6.12	4.0	4.3	9.6	24
1-1/2"	600	6.12	4.0	4.3	9.9	25	6.12	4.0	4.3	9.9	26
1-1/2"	900/1500	7.00	4.0	4.3	10.6	36	7.00	4.0	4.3	10.6	38
1-1/2"	2500	8.00	4.0	4.3	11.6	57	8.00	4.0	4.3	11.7	61
2"	150	6.00	4.0	4.3	9.1	21	6.00	4.0	4.3	9.5	23
2"	300	6.50	4.0	4.3	9.4	25	6.50	4.0	4.3	9.9	27
2"	600	6.50	4.0	4.3	10.1	29	6.50	4.0	4.3	10.2	31
2"	900/1500	8.50	4.0	4.3	11.1	56	8.50	4.0	4.3	11.2	59
2"	2500	9.25	4.0	4.3	12.1	81	9.25	4.0	4.3	12.2	85



HK12 & HK22 NPT x NPT Hexblok - Ball Valve

- 1/4", 1/2", 9/16", 3/4", 1" sizes available.
For special size, please contact factory.
- Forged body design provides strength needed to handle the higher pressures while keeping the overall dimensions small.
- Block and bleed version eliminates weight, space, and cost.
- Less labor cost for installation of one valve instead of two.
- Pressure ranges up to 6,000 psi.

HK12

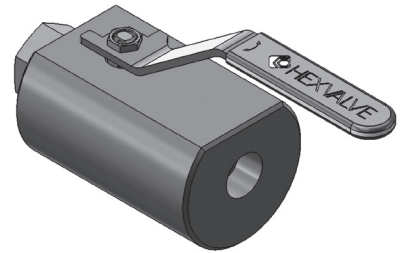

HK22

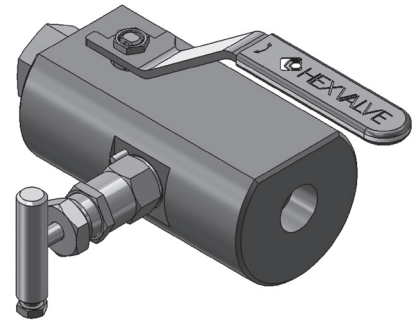

Dimensions

HK12

Weight = 7 lbs

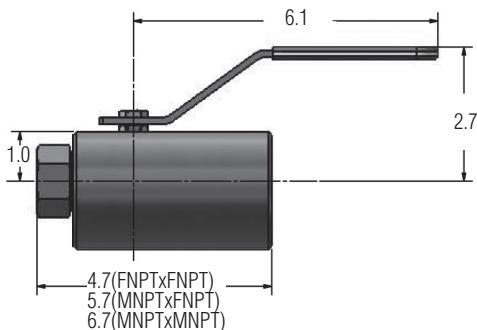
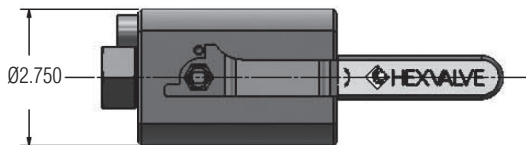

HK22

Weight = 9 lbs

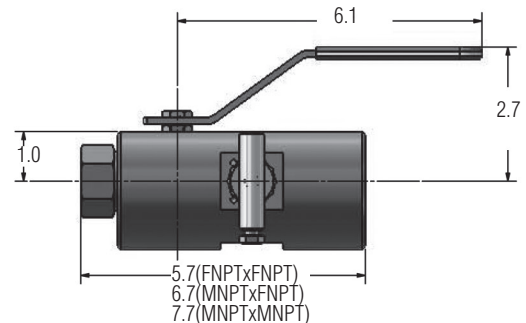
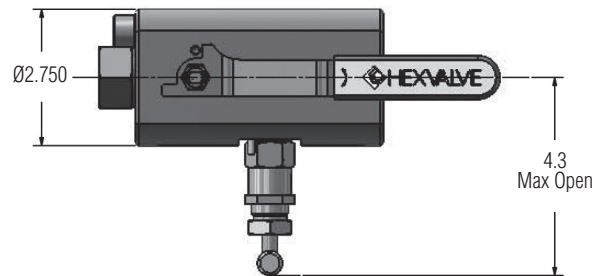



HK32 NPT x NPT Hexblok - Ball Valve

- 1/4", 1/2", 9/16", 3/4", 1" sizes available.
- The Hexblok Double Block and Bleed valve incorporates three valves into one, bringing the overall dimensional size down to a convenient compact package.
- Pressure ranges up to 6,000 psi.
- Less leak points, less weight and small size make this the valve of choice on instrument pressuer points.

Standard Body

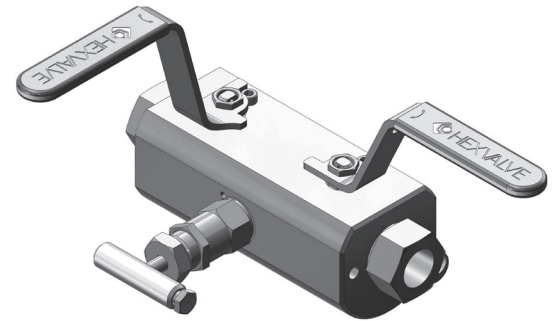

Square Body with Mounting Holes

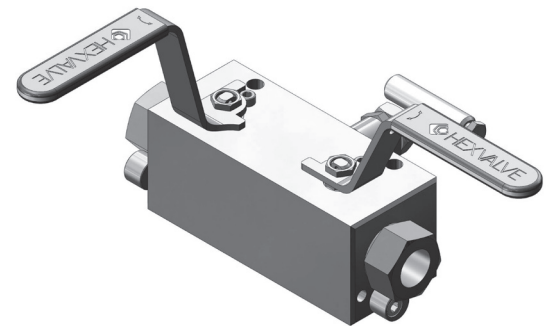

Dimensions (1/2" & 3/4" NPT shown)

HK32 Standard
Weight = 9.5 lbs

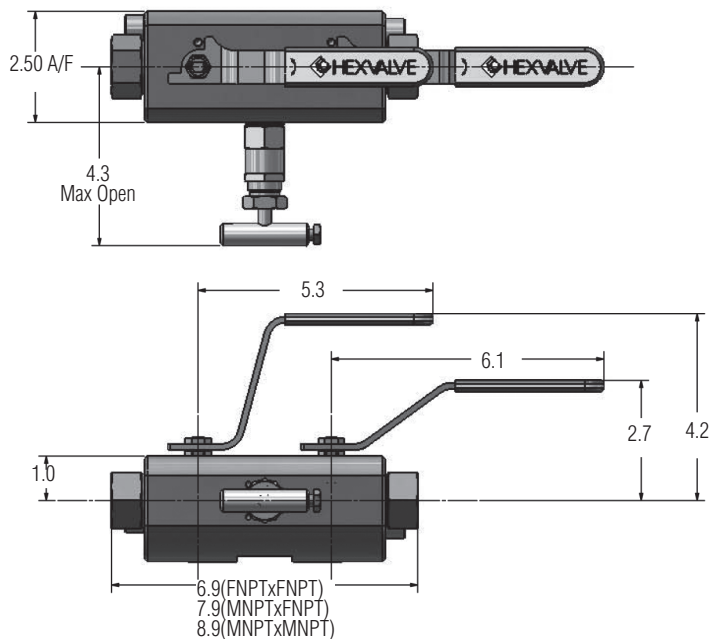

HK32 Square Body
Weight = 9 lbs

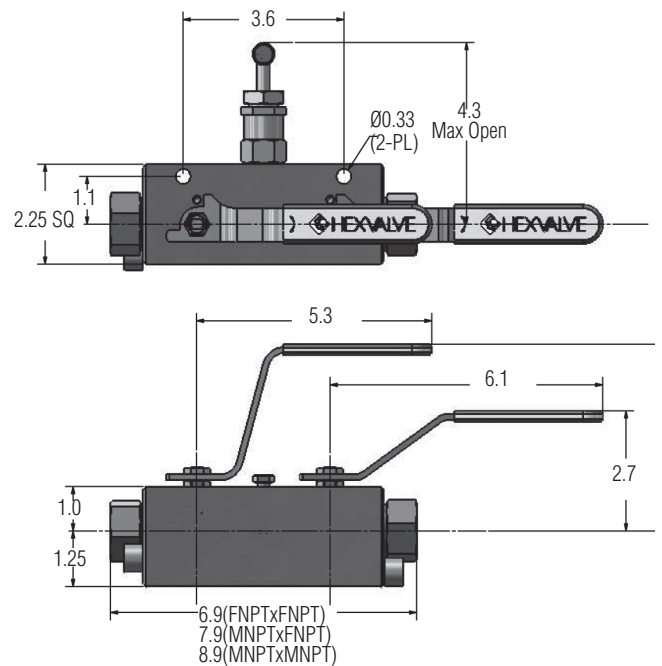



Sample Quills & Injection Probes

- The Sampling Probe or Injection Quill Double Block and Bleed valves are designed for safety in these hazardous applications.
- Integral check valve standard w/ injection quill, optional for sampling probe.
- Custom designs and lengths available per customer application.
- NACE valves available.
- Many materials of construction are available (Stainless Steel, Duplex, Super-Duplex, etc.)

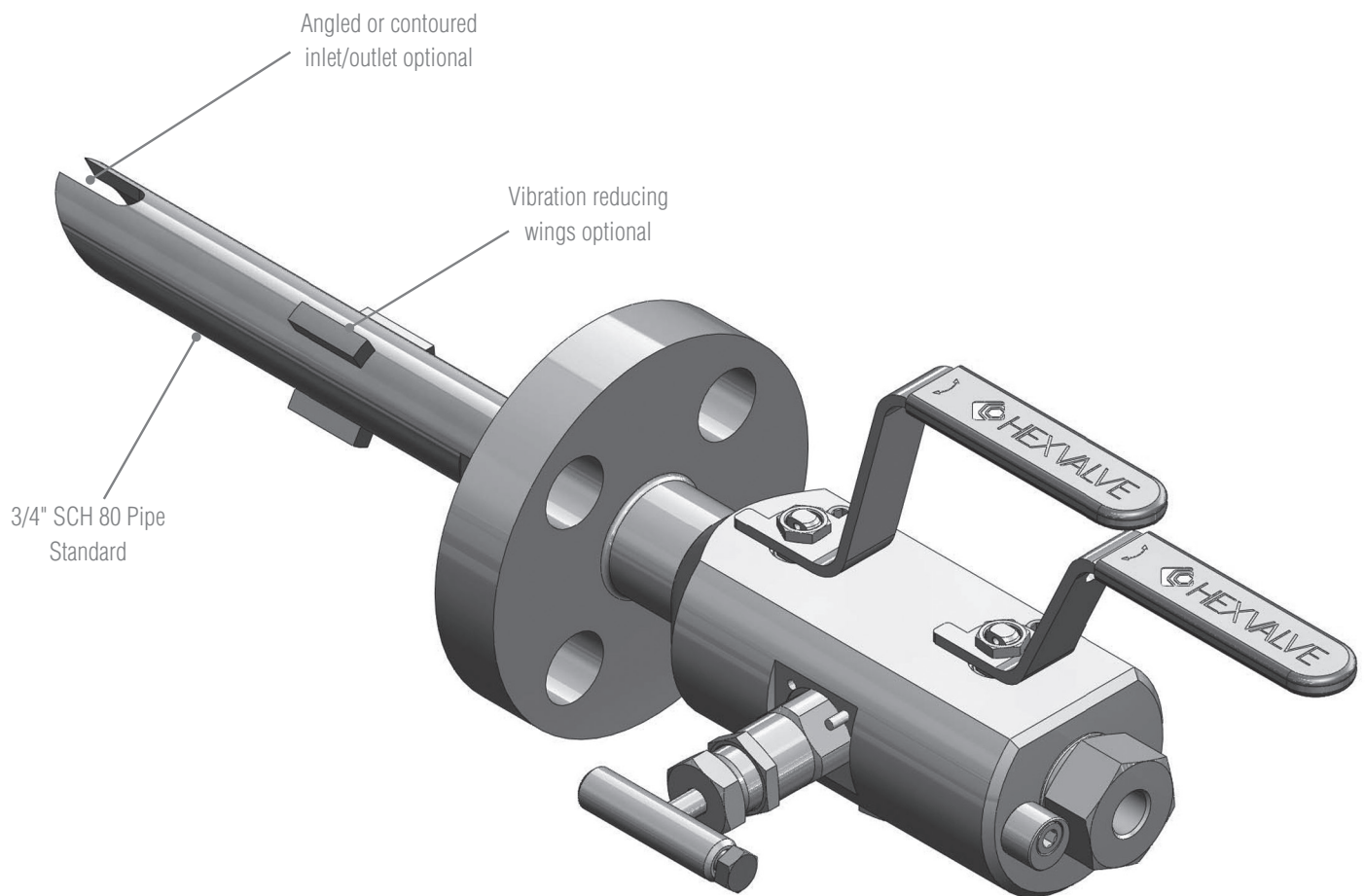
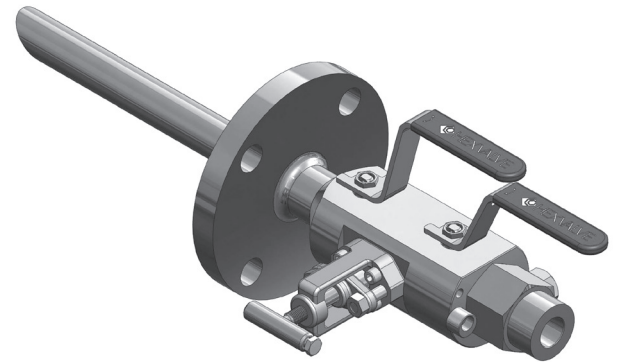



Materials of Construction - Hexblok Ball Valve

Item	Description	Material Code 'U'/'D'	Material Code 'Y'/'3'	Material Code 'P'/'N'	Exotic (Note 2)
1	Body	316SS / 316 SS Nace	316L SS / 316L SS Nace	A105 / A105 Nace (Note 1)	Exotic
2	Ball	316SS / 316 SS Nace	316L SS / 316L SS Nace	316 SS/316 SS NACE	Exotic
3	Ball Stem	316SS / 316 SS Nace	316L SS / 316L SS Nace	316 SS/316 SS NACE	Exotic
4	Ball Stem Packing	PTFE or Graphite	PTFE or Graphite	PTFE or Graphite	PTFE or Graphite
5	Ball Stem O-ring	Viton	Viton	Viton	Viton
6	Seats	PEEK or Carbon PEEK	PEEK or Carbon PEEK	PEEK or Carbon PEEK	PEEK or Carbon PEEK
7	Gasket-Metal	316 SS / 316 SS Nace	316L SS / 316L SS Nace	316 SS/316 SS NACE	Exotic
8	Gasket-Soft	PEEK or Carbon PEEK	PEEK or Carbon PEEK	PEEK or Carbon PEEK	PEEK or Carbon PEEK
9	Handle	304SS	304 SS	304 SS	304 SS
10	Inlet Retainer	316 SS / 316 SS Nace	316L SS / 316L SS Nace	A105 / A105 Nace (Note 1)	Exotic
11	Outlet Retainer	316 SS / 316 SS Nace	316L SS / 316L SS Nace	A105 / A105 Nace (Note 1)	Exotic
12	Bleed Bonnet	316 SS / 316 SS Nace	316L SS / 316L SS Nace	316 SS/316 SS NACE	Exotic

Notes:

- 1 - Carbon steel valve bodies and components are zinc plated
- 2 - See product designator (next page) for full list of materials

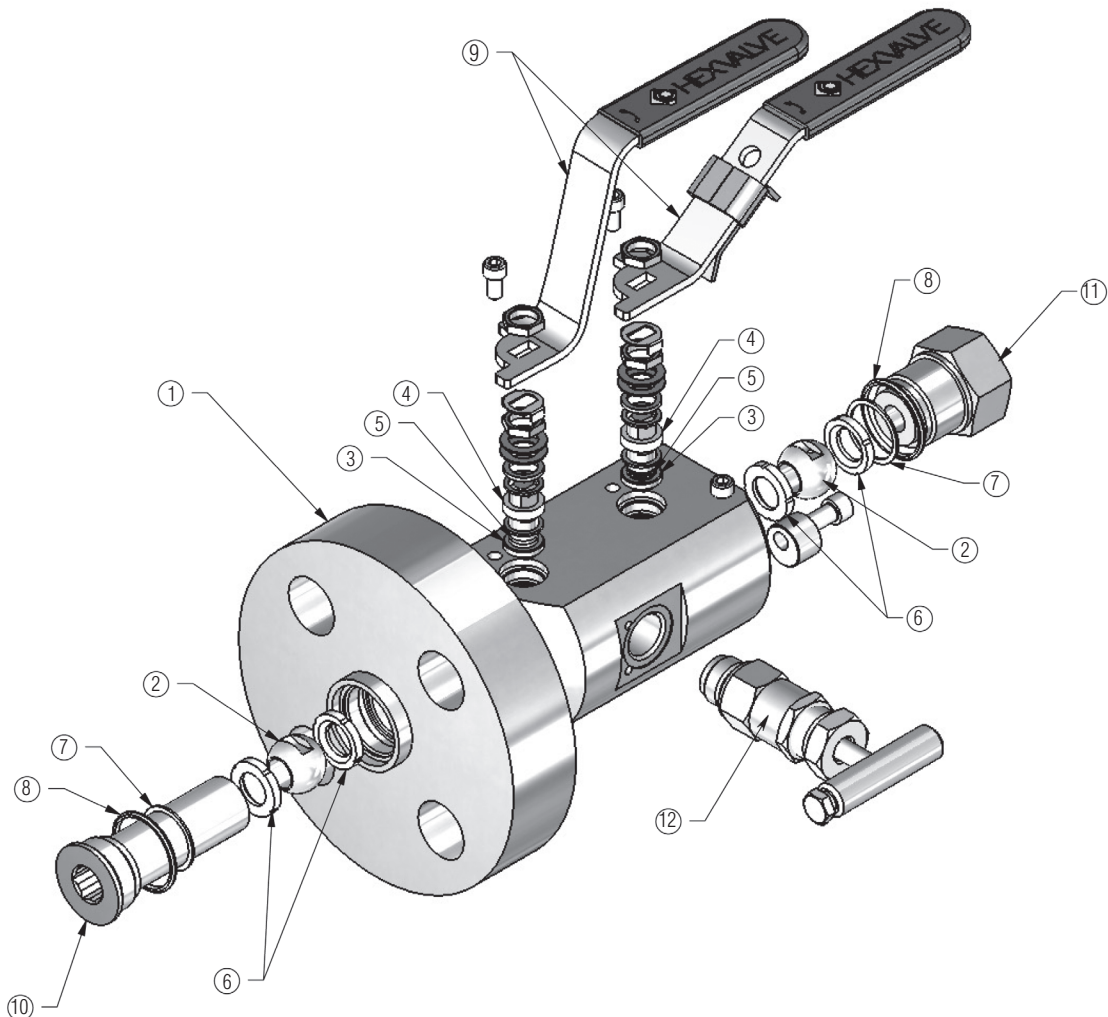



MODEL	BODY CONFIG.	BODY MAT'L	INLET SIZE	INLET TYPE	OUTLET SIZE	OUTLET TYPE	BALL & STEM/TIP	BALL SEAT MAT'L	PACKING	OPTION	OPTION
HK22	2	6	3	C	3	1	4	2	3	A	9

MODEL	TYPE
HK12	Single Block Ball
HK22	Single Block Ball & Bleed (vent)
HK32	*Double Block Ball & Bleed (vent)
HK42	**Double Block Ball & Bleed (vent)

*Block > Bleed > Block configuration

**Block > Block > Bleed configuration

BODY CONFIGURATION	
2	10mm Soft Seat Block Valve(s)
4	15mm Soft Seat Block Valve(s)
5	20mm Soft Seat Block Valve(s)
6	25mm Soft Seat Block Valve(s)

Vent valve always hard seat

BODY MATERIAL	
U	316SS
D	316SS NACE (forged)
Y	A182F 316L (forged)
3	A182F 316L NACE (forged)
P	Carbon Steel A105
N	Carbon Steel, A105 NACE
6	Duplex A182 F51 (forged)
4	Super Duplex A182 F55 (forged)
H	Hastelloy C
X	Alloy 20
K	Low Temp CS A350 LF2 (forged)
7	Inconel 625
I	Incoloy 825
M	Monel 400 (forged)

INLET SIZE	
1	1/4"
2	3/8"
3	1/2" (DN15)
4	3/4" (DN20)
5	1" (DN25)
6	1-1/2" (DN40)
7	2" (DN50)

INLET TYPE	
1	MNPT
3	FNPT
4	FSW
C	150# RF
D	300# RF
G	600# RF
H	900/1500# RF
K	2500# RF
L	150# RTJ
M	300# RTJ
N	600# RTJ
P	900/1500# RTJ
R	2500# RTJ

OUTLET SIZE	
1	1/4" (DN8)
2	3/8" (DN10)
3	1/2" (DN15)
4	3/4" (DN20)
5	1" (DN25)
6	1-1/2" (DN40)
7	2" (DN50)
9	Flanged - Same as inlet

OUTLET TYPE	
1	FNPT
7	MNPT
2	FSW
9	Flanged - Same as inlet

BALL & STEM / NRT (VENT VALVE)	
4	316/316 Stem w/ NRT tip
3	316/316 NACE Stem w/ NRT tip
5	316/Stellite Stem w/ NRT tip
K	316/Monel Stem w/ NRT tip
Y	316L/316L Stem w/ NRT tip
A	316L/316L NACE Stem w/ NRT tip
M	Duplex/Duplex Stem w/ NRT tip
C	Super Duplex/Super Duplex Stem w/ NRT tip
D	Hastelloy C/Hastelloy C Stem w/ NRT tip
G	Alloy 20/Alloy 20 Stem w/ NRT tip
6	I-625/I-625 Stem w/ NRT tip
7	I-825/I-825 Stem w/ NRT tip
B	Monel/Monel Stem w/ NRT tip

Note: For different NRT tip material, contact factory

BALL SEAT MATERIAL	
3	PEEK (standard)
4	C-PEEK

Contact factory for other seat materials

PACKING	
2	Teflon Packing
3	Graphite Packing (fire safe selection)

OPTIONS*	
M	Two Outlets
N	Three Outlets
6	100% 316 non-wet parts
S	Swivel Adapter**
C	Plugged vent option (same material as body)
V	OS&Y Bonnet - Vent Valve
D	1/4" Vent Port
F	3/4" Vent Port
9	Tamper Proof/Lockout Handle - Vent Valve
K	10mm Vent Bore

*Note: Choose any two options in alpha-numerical order

**Consult factory for swivel adapter ordering options

Specifications: Globe Style Valves

WORKING PRESSURE

- In accordance to ASME B16.5 for class 150 to 2500

WORKING TEMPERATURES

- 450°F (232°C) for Teflon packing
- 1000°F (528°C) for Graphite packing

CERTIFICATIONS

- API 607 5th Edition (Fire Test)
- ASME VIII (pressure boundaries)
- PED
- ANSI B16.5 (flange dimensions)
- EN 10204.3.1 (material traceability)

SIZES

- 1/2" through 2"
- 10mm Bore/Orifice sizes

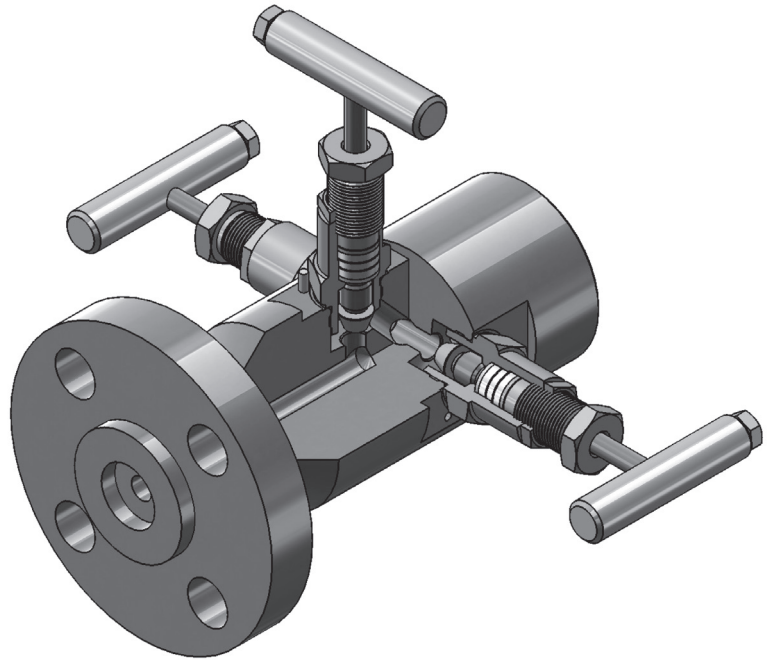

HEXBLOK ADVANTAGES & CUSTOMER BENEFITS

- Large, 3/8" (10mm) standard orifice and porting, resulting in a lower probability of plugging.
- OBS (Outer Bonnet Support) design provides the security of OS&Y bonnets with the packing maintenance ease of a screwed bonnet.
- Optional "Zerk" style high pressure grease fitting option ensures long term stem/valve life, and easier stem operation. Internal porting deploys grease where it is needed most: above the packing and into the stem threads, for lubrication and environmental protection.
- Large, robust bonnet and NRT stem design means higher probability of long life, and less break risk than competitive designs
- Hex was the first in the industry to utilize Non-Rotating Stem Tip (NRT) technology. When the stem tip contacts the seat, it stops rotating, preventing the cross scoring and eventual leaks that can occur with ball type stems
- 4 rings Teflon Chevron style packing, or multi-ring set of grafoil surrounded by braided graphite standard.
- API 607 5th Edition (fire test) Standard (Graphite-packed and hard seat models only)
- Large variety of standard and optional forged or bar materials and outlet options, means you can select the style and material you need immediately from catalog, instead of having to contact the factory
- Special built-to-order design inquiries welcome



Hexblok Valves: Globe Style Valves - OBS Bonnet

"Zerk" style grease fitting option ensures long term life, and ease of operation of your HexBlok assets. Internal porting deploys grease where it is needed: above the packing and into the stem threads

Outer Bonnet Support (OBS) provides the security of OS&Y bonnets with the packing maintenance ease of a screwed bonnet

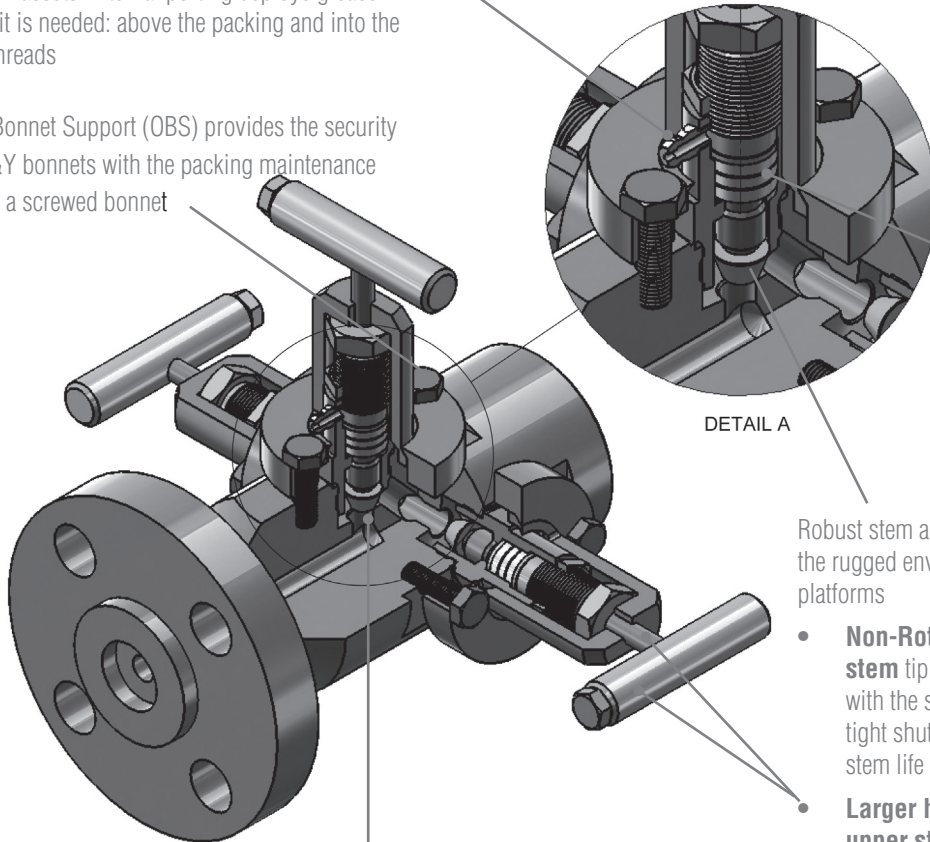

4 rings Teflon Chevron style packing, or multi-ring set of grafoil surrounded by braided graphite (fire safe selection) standard.

DETAIL A

Robust stem and bonnet can withstand the rugged environment of offshore platforms

- **Non-Rotating conical plug stem tip** forms a consistent mate with the seat, ensuring bubble tight shutoff and prolonged seat/stem life

- **Larger handle and thicker upper stem** promote easier handle operation especially with high temperature packing sets. Lower probability of stem breaks or damage than other designs on the market

3/8" (10mm) standard orifice and porting means lower probability of plugging than all other competitive designs

Note: Bonnet stop pin standard on screwed bonnets. Competitor's hollow spring steel pins can corrode and crack in salt water or corrosive ambient environments.

- 1/2" - 14 NPT, FSW, Tube Socket, and Multiport Gauge Outlet options are standard selections (note: vent is 1/2" FNPT)
- Standard materials of construction: A182F 316L (forged), Hastelloy C, Incoloy 800, Inconel 600, Low Temp CS A350 LF2 (forged), Monel 400 (forged), Carbon Steel, A105 NACE, Carbon Steel A105, A182F 316L NACE (forged), Duplex A182 F51 (forged), Inconel (625), Super Duplex A182F55 (forged)
- Screwed bonnet and OBS bonnets available
- Raised face (RF) and Ring Type Joint (RTJ) flange styles standard



Non-Rotating Tip (NRT) conical plug stem forms consistent mate with the seat ensuring bubble tight shutoff and prolonged stem and seat life

Robust stem and bonnet construction. Can withstand the rugged environment of offshore platforms better than any other design on the market

Combination anti-tamper with lock-out bonnet option

Rising stem plug style valve permits straight through porting (for rodout) with a traditional bonnet design (body configuration # 2)

One piece close fit forging, or barstock construction

Solid bonnet stop pin standard. Hollow spring steel pins can corrode and crack in salt water, or corrosive ambient environments

3/8" (10mm) standard orifice and porting means lower probability of plugging than all other competitive designs

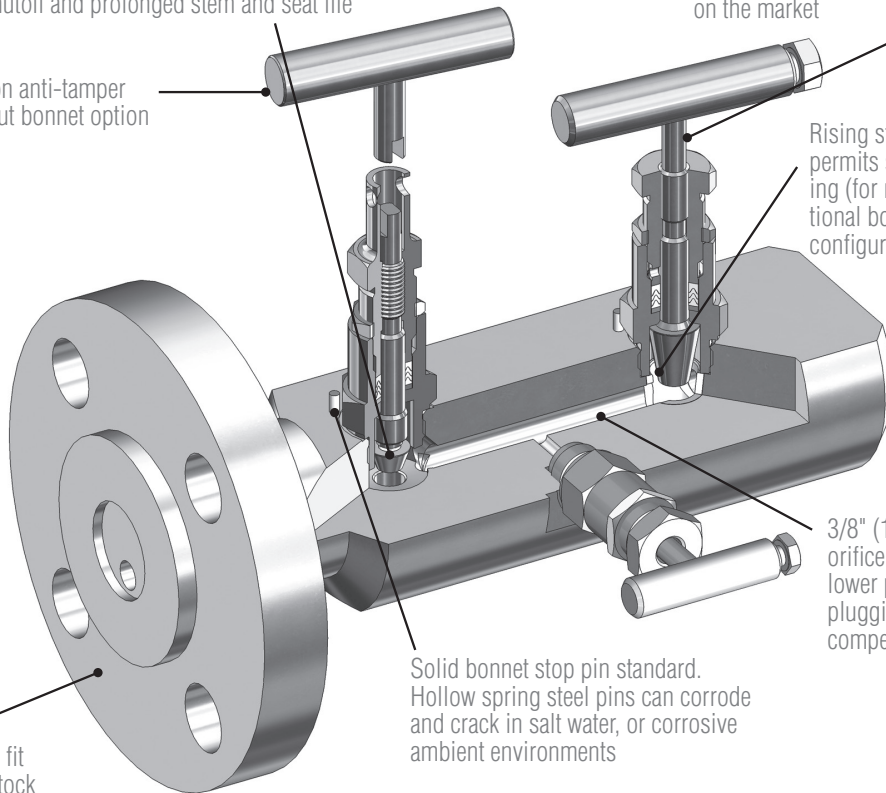

1/2" - 14 NPT, FNPT vent port standard

Flow Schematic



For Models: **HK10, HK11**

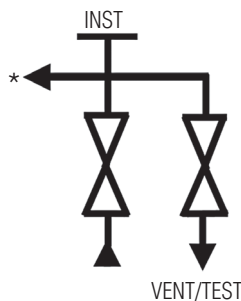

HK20, HK21

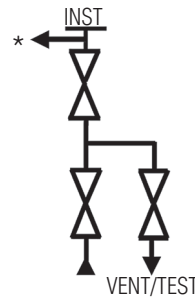

HK30, HK31

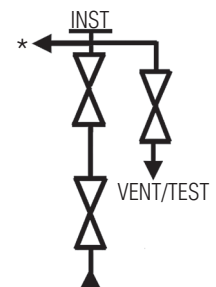

HK40, HK41

* Side instrument outlet available as option



Hexblok Needle Valve Dimensions & Weights - HK10/11 Single Flange

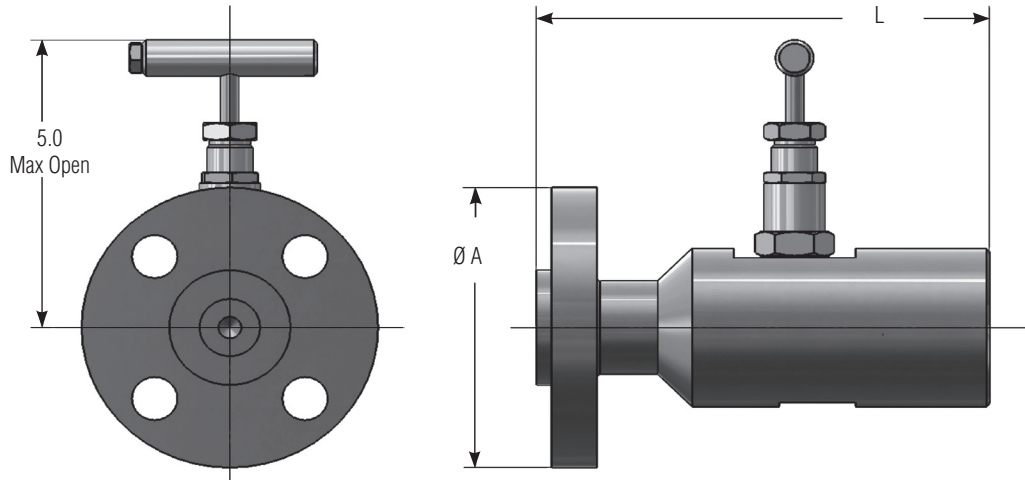

Flange Size	B16.34 Pressure Class	HK10/11 RF Single Flange				HK10/11 RTJ Single Flange			
		A	L	Weight HK10	Weight HK11	A	L	Weight HK10	Weight HK 11
1/2"	150	3.50	7.0	12	13	N/A	N/A	N/A	N/A
1/2"	300	3.75	7.1	12	13	3.75	7.2	13	14
1/2"	600	3.75	7.3	12	13	3.75	7.3	13	14
1/2"	900/1500	4.75	7.7	15	16	4.75	7.7	15	16
1/2"	2500	5.25	8.0	17	18	5.25	8.0	18	19
3/4"	150	3.88	7.0	12	13	N/A	N/A	N/A	N/A
3/4"	300	4.62	7.1	14	15	4.62	7.3	14	15
3/4"	600	4.62	7.4	14	15	4.62	7.4	14	15
3/4"	900/1500	5.12	7.8	16	17	5.12	7.8	17	18
3/4"	2500	5.50	8.0	19	20	5.50	8.0	19	20
1"	150	4.25	7.1	13	14	4.25	7.3	13	14
1"	300	4.88	7.2	13	14	4.88	7.4	14	15
1"	600	4.88	7.5	14	15	4.88	7.5	15	16
1"	900/1500	5.88	7.9	19	20	5.88	7.9	19	20
1"	2500	6.25	8.2	22	23	6.25	8.2	23	24
1-1/2"	150	5.00	7.2	14	15	5.00	7.4	15	16
1-1/2"	300	6.12	7.3	17	18	6.12	7.5	17	18
1-1/2"	600	6.12	7.7	18	19	6.12	7.7	19	20
1-1/2"	900/1500	7.00	8.0	24	25	7.00	8.0	24	25
1-1/2"	2500	8.00	8.5	34	35	8.00	8.6	35	36
2"	150	6.00	7.3	16	17	6.00	7.5	17	18
2"	300	6.50	7.4	18	19	6.50	7.6	19	20
2"	600	6.50	7.8	20	21	6.50	7.8	21	22
2"	900/1500	8.50	8.3	34	35	8.50	8.3	34	35
2"	2500	9.25	8.8	46	47	9.25	8.8	47	48



Hexblok Needle Valve Dimensions & Weights - HK20/21 Single Flange

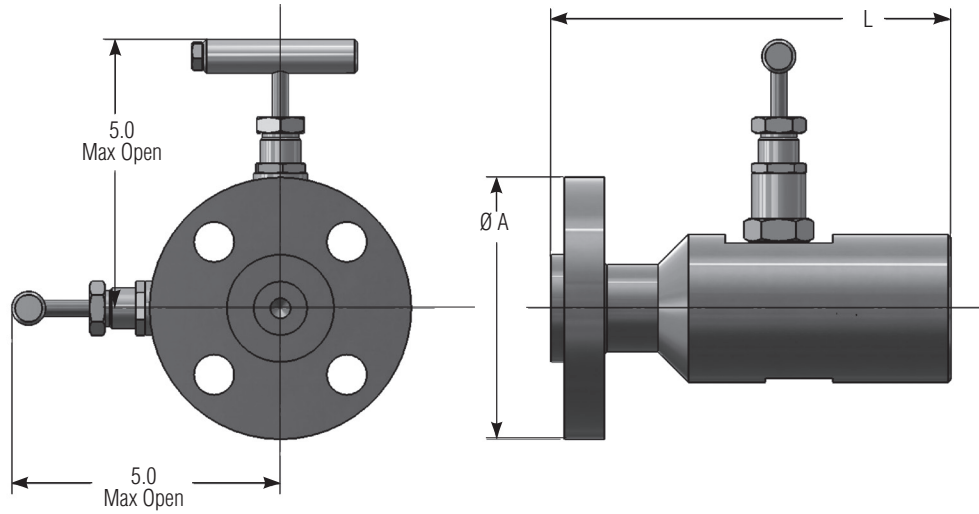

Flange Size	B16.34 Pressure Class	HK20/21 RF Single Flange				HK20/21 RTJ Single Flange			
		A	L	Weight HK20	Weight HK21	A	L	Weight HK20	Weight HK21
1/2"	150	3.50	7.0	12	14	N/A	N/A	N/A	N/A
1/2"	300	3.75	7.1	13	15	3.75	7.2	13	15
1/2"	600	3.75	7.3	13	15	3.75	7.3	13	15
1/2"	900/1500	4.75	7.7	15	17	4.75	7.7	16	18
1/2"	2500	5.25	8.0	18	20	5.25	8.0	19	21
3/4"	150	3.88	7.0	13	15	N/A	N/A	N/A	N/A
3/4"	300	4.62	7.1	14	16	4.62	7.3	14	16
3/4"	600	4.62	7.4	14	16	4.62	7.4	14	16
3/4"	900/1500	5.12	7.8	17	19	5.12	7.8	17	19
3/4"	2500	5.50	8.0	19	21	5.50	8.0	20	22
1"	150	4.25	7.1	13	15	4.25	7.3	14	16
1"	300	4.88	7.2	14	16	4.88	7.4	15	17
1"	600	4.88	7.5	15	17	4.88	7.5	15	17
1"	900/1500	5.88	7.9	19	21	5.88	7.9	20	22
1"	2500	6.25	8.2	23	25	6.25	8.2	23	25
1-1/2"	150	5.00	7.2	15	17	5.00	7.4	15	17
1-1/2"	300	6.12	7.3	17	19	6.12	7.5	18	20
1-1/2"	600	6.12	7.7	19	21	6.12	7.7	19	21
1-1/2"	900/1500	7.00	8.0	24	26	7.00	8.0	25	27
1-1/2"	2500	8.00	8.5	35	37	8.00	8.6	37	39
2"	150	6.00	7.3	17	19	6.00	7.5	18	20
2"	300	6.50	7.4	19	21	6.50	7.6	20	22
2"	600	6.50	7.8	21	23	6.50	7.8	22	24
2"	900/1500	8.50	8.3	34	36	8.50	8.3	36	38
2"	2500	9.25	8.8	47	49	9.25	8.8	49	51



Hexblok Needle Valve Dimensions & Weights - HK30/31, HK40/41 Single Flange

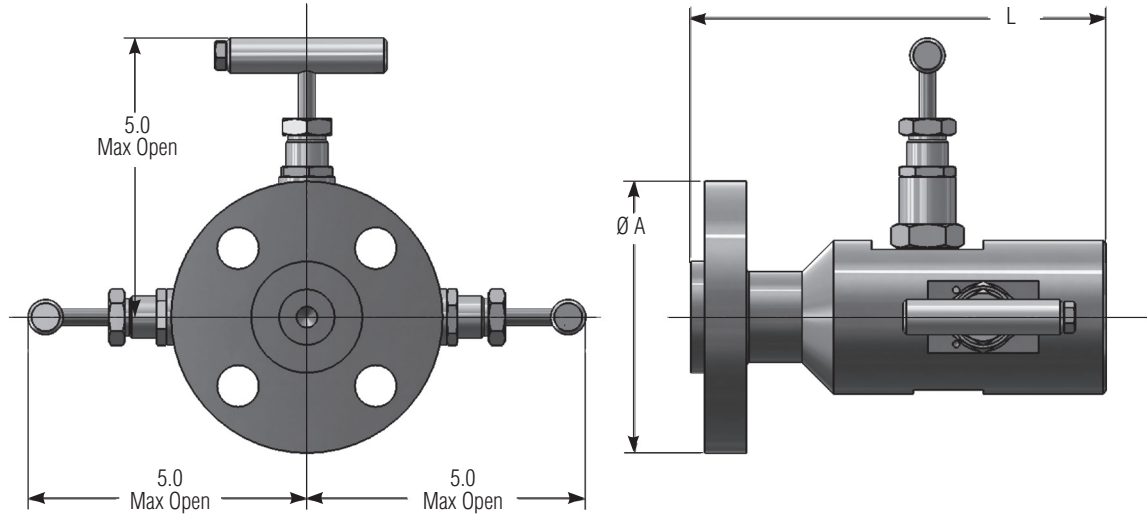

Flange Size	B16.34 Pressure Class	HK30/31 RF Single Flange				HK30/31 RTJ Single Flange			
		A	L	Weight HK30	Weight HK31	A	L	Weight HK30	Weight HK31
1/2"	150	3.50	7.0	13	16	N/A	N/A	N/A	N/A
1/2"	300	3.75	7.1	14	17	3.75	7.2	14	17
1/2"	600	3.75	7.3	14	17	3.75	7.3	14	17
1/2"	900/1500	4.75	7.7	16	19	4.75	7.7	17	20
1/2"	2500	5.25	8.0	19	22	5.25	8.0	20	23
3/4"	150	3.88	7.0	14	17	N/A	N/A	N/A	N/A
3/4"	300	4.62	7.1	15	18	4.62	7.3	15	18
3/4"	600	4.62	7.4	15	18	4.62	7.4	15	18
3/4"	900/1500	5.12	7.8	18	21	5.12	7.8	18	21
3/4"	2500	5.50	8.0	20	23	5.50	8.0	21	24
1"	150	4.25	7.1	14	17	4.25	7.3	15	18
1"	300	4.88	7.2	15	18	4.88	7.4	16	19
1"	600	4.88	7.5	16	19	4.88	7.5	16	19
1"	900/1500	5.88	7.9	20	23	5.88	7.9	21	24
1"	2500	6.25	8.2	24	27	6.25	8.2	24	27
1-1/2"	150	5.00	7.2	16	19	5.00	7.4	16	19
1-1/2"	300	6.12	7.3	18	21	6.12	7.5	19	22
1-1/2"	600	6.12	7.7	20	23	6.12	7.7	20	23
1-1/2"	900/1500	7.00	8.0	25	28	7.00	8.0	26	29
1-1/2"	2500	8.00	8.5	36	39	8.00	8.6	38	41
2"	150	6.00	7.3	18	21	6.00	7.5	19	22
2"	300	6.50	7.4	20	23	6.50	7.6	21	24
2"	600	6.50	7.8	22	25	6.50	7.8	23	26
2"	900/1500	8.50	8.3	35	38	8.50	8.3	37	40
2"	2500	9.25	8.8	48	51	9.25	8.8	50	53



Hexblok Needle Valve Dimensions & Weights - HK10/11 Double Flange

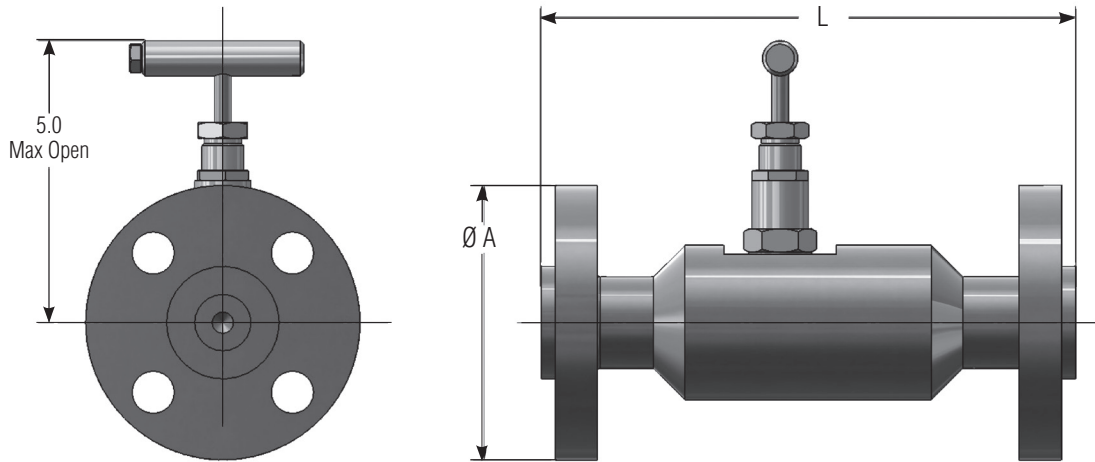

Flange Size	B16.34 Pressure Class	HK10/11 RF Double Flange				HK10/11 RTJ Double Flange			
		A	L	Weight HK10	Weight HK11	A	L	Weight HK10	Weight HK11
1/2"	150	3.50	8.5	15	16	N/A	N/A	N/A	N/A
1/2"	300	3.75	8.7	16	17	3.75	9.1	15	16
1/2"	600	3.75	9.2	16	17	3.75	9.2	16	17
1/2"	900/1500	4.75	9.9	21	22	4.75	9.9	21	22
1/2"	2500	5.25	10.5	26	27	5.25	10.5	27	28
3/4"	150	3.88	8.6	16	17	N/A	N/A	N/A	N/A
3/4"	300	4.62	8.9	19	20	4.62	9.2	18	19
3/4"	600	4.62	9.4	19	20	4.62	9.4	18	19
3/4"	900/1500	5.12	10.1	24	25	5.12	10.1	24	25
3/4"	2500	5.50	10.6	29	30	5.50	10.6	29	30
1"	150	4.25	8.7	17	18	4.25	9.1	17	18
1"	300	4.88	9.0	18	19	4.88	9.4	19	20
1"	600	4.88	9.5	20	21	4.88	9.5	20	21
1"	900/1500	5.88	10.4	29	30	5.88	10.4	29	30
1"	2500	6.25	10.9	36	37	6.25	10.9	36	37
1-1/2"	150	5.00	9.0	20	21	5.00	9.4	20	21
1-1/2"	300	6.12	9.2	25	26	6.12	9.6	26	27
1-1/2"	600	6.12	9.9	28	29	6.12	9.9	28	29
1-1/2"	900/1500	7.00	10.6	39	40	7.00	10.6	40	41
1-1/2"	2500	8.00	11.6	60	61	8.00	11.7	63	64
2"	150	6.00	9.1	24	25	6.00	9.5	25	26
2"	300	6.50	9.4	28	29	6.50	9.9	29	30
2"	600	6.50	10.1	32	33	6.50	10.2	33	34
2"	900/1500	8.50	11.1	59	60	8.50	11.2	61	62
2"	2500	9.25	12.1	84	85	9.25	12.2	87	88



Hexblok Needle Valve Dimensions & Weights - HK20/21 Double Flange

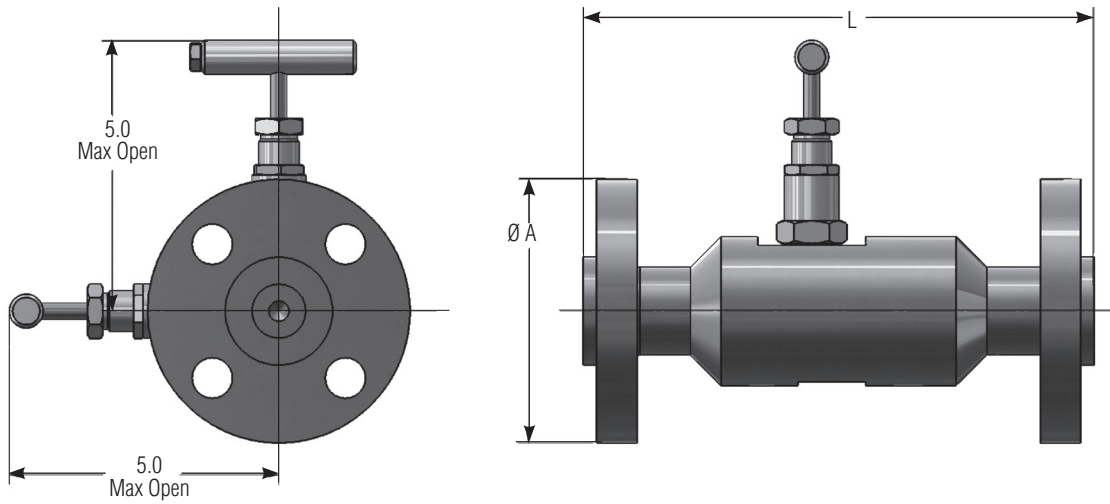

Flange Size	B16.34 Pressure Class	HK20/21 RF Double Flange				HK20/21 RTJ Double Flange			
		A	L	Weight HK20	Weight HK21	A	L	Weight HK20	Weight HK21
1/2"	150	3.50	8.5	16	18	N/A	N/A	N/A	N/A
1/2"	300	3.75	8.7	17	19	3.75	9.1	16	18
1/2"	600	3.75	9.2	17	19	3.75	9.2	17	19
1/2"	900/1500	4.75	9.9	22	24	4.75	9.9	22	24
1/2"	2500	5.25	10.5	27	29	5.25	10.5	28	30
3/4"	150	3.88	8.6	17	19	N/A	N/A	N/A	N/A
3/4"	300	4.62	8.9	20	22	4.62	9.2	19	21
3/4"	600	4.62	9.4	20	22	4.62	9.4	19	21
3/4"	900/1500	5.12	10.1	25	27	5.12	10.1	25	27
3/4"	2500	5.50	10.6	30	32	5.50	10.6	30	32
1"	150	4.25	8.7	18	20	4.25	9.1	18	20
1"	300	4.88	9.0	19	21	4.88	9.4	20	22
1"	600	4.88	9.5	21	23	4.88	9.5	21	23
1"	900/1500	5.88	10.4	30	32	5.88	10.4	30	32
1"	2500	6.25	10.9	37	39	6.25	10.9	37	39
1-1/2"	150	5.00	9.0	21	23	5.00	9.4	21	23
1-1/2"	300	6.12	9.2	26	28	6.12	9.6	27	29
1-1/2"	600	6.12	9.9	29	31	6.12	9.9	29	31
1-1/2"	900/1500	7.00	10.6	40	42	7.00	10.6	41	43
1-1/2"	2500	8.00	11.6	61	63	8.00	11.7	64	66
2"	150	6.00	9.1	25	27	6.00	9.5	26	28
2"	300	6.50	9.4	29	31	6.50	9.9	30	32
2"	600	6.50	10.1	33	35	6.50	10.2	34	36
2"	900/1500	8.50	11.1	60	62	8.50	11.2	62	64
2"	2500	9.25	12.1	85	87	9.25	12.2	88	90



Hexblok Needle Valve Dimensions & Weights - HK30/31, HK 40/41 Double Flange

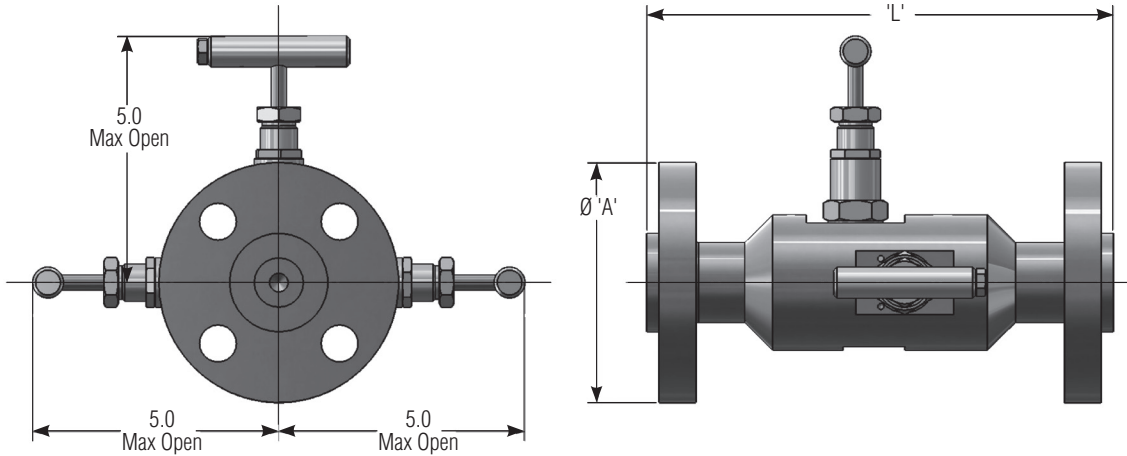

Flange Size	B16.34 Pressure Class	HK30/31 RF Double Flange			HK30/31 RTJ Double Flange				
		A	L	Weight HK30	Weight HK31	A	L	Weight HK30	Weight HK31
1/2"	150	3.50	8.5	17	20	N/A	N/A	N/A	N/A
1/2"	300	3.75	8.7	18	21	3.75	9.1	17	20
1/2"	600	3.75	9.2	18	21	3.75	9.2	18	21
1/2"	900/1500	4.75	9.9	23	26	4.75	9.9	23	26
1/2"	2500	5.25	10.5	28	31	5.25	10.5	29	32
3/4"	150	3.88	8.6	18	21	N/A	N/A	N/A	N/A
3/4"	300	4.62	8.9	21	24	4.62	9.2	20	23
3/4"	600	4.62	9.4	21	24	4.62	9.4	20	23
3/4"	900/1500	5.12	10.1	26	29	5.12	10.1	26	29
3/4"	2500	5.50	10.6	31	34	5.50	10.6	31	34
1"	150	4.25	8.7	19	22	4.25	9.1	19	22
1"	300	4.88	9.0	20	23	4.88	9.4	21	24
1"	600	4.88	9.5	22	25	4.88	9.5	22	25
1"	900/1500	5.88	10.4	31	34	5.88	10.4	31	34
1"	2500	6.25	10.9	38	41	6.25	10.9	38	41
1-1/2"	150	5.00	9.0	22	25	5.00	9.4	22	25
1-1/2"	300	6.12	9.2	27	30	6.12	9.6	28	31
1-1/2"	600	6.12	9.9	30	33	6.12	9.9	30	33
1-1/2"	900/1500	7.00	10.6	41	44	7.00	10.6	42	45
1-1/2"	2500	8.00	11.6	62	65	8.00	11.7	65	68
2"	150	6.00	9.1	26	29	6.00	9.5	27	30
2"	300	6.50	9.4	30	33	6.50	9.9	31	34
2"	600	6.50	10.1	34	37	6.50	10.2	35	38
2"	900/1500	8.50	11.1	61	64	8.50	11.2	63	66
2"	2500	9.25	12.1	86	89	9.25	12.2	89	92

NPT x NPT Hexblok - Needle Valve

- 1/4", 1/2", 9/16", 3/4", 1" sizes available.
- Forged body design provides the strength needed to keep this valve small and compact.
- Pressure ranges of 6,000 psi and 10,000 psi.
- Lower cost, less weight, and smaller size than standard piping methods makes this the perfect valve for instrumentation pressure points.
- Available in many grades of material (Stainless Steel, Duplex, Super-Duplex, etc.)

HK30 MNPTxFNPT

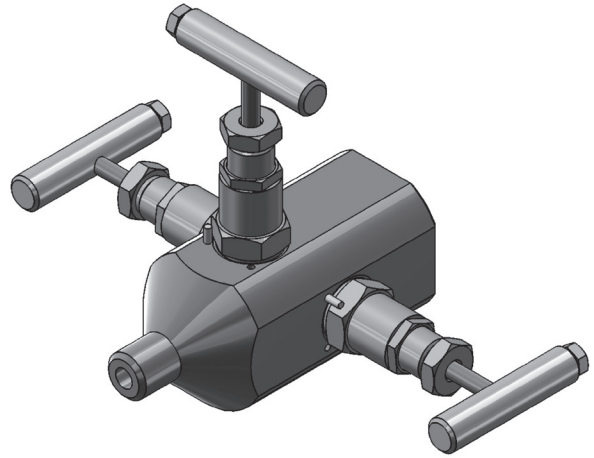

MNPTxFNPT (HK30 Shown)

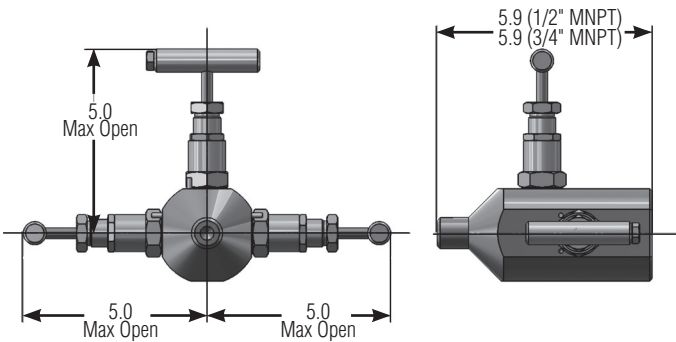

FNPTxFNPT (HK30 Shown)

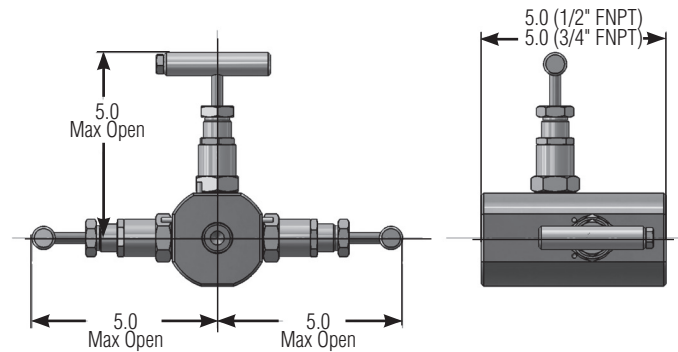

10,000 PSI MNPTxFNPT (HK30 Shown)

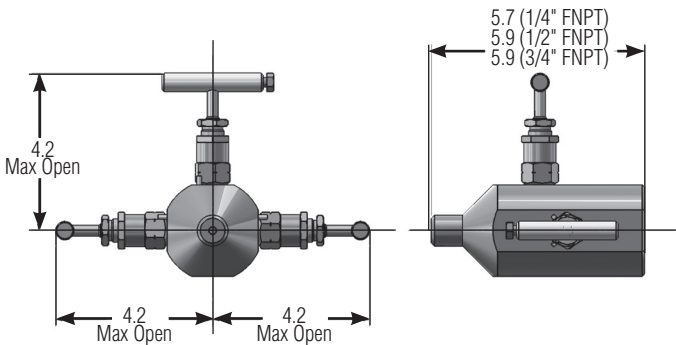

10,000 PSI FNPTxFNPT (HK30 Shown)

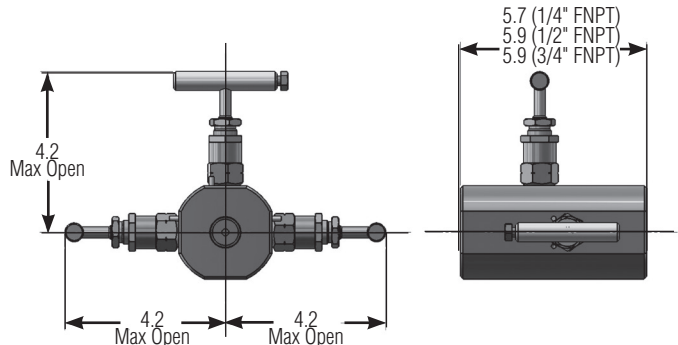



Materials of Construction - Hexblok Globe Style Valve

Item	Description	Material Code 'U' / 'D'	Material Code 'Y' / '3'	Material Code 'P' / 'N'	Exotic (Note 2)
1	Body	316 SS / 316 SS Nace	316L SS / 316L SS Nace	A105 / A105 Nace (Note 1)	Exotic
2	Bonnet	316 SS / 316 SS Nace	316L SS / 316L SS Nace	316 SS / 316 SS Nace	Exotic
3	Packing Follower	303 SS	303 SS	303 SS	303 SS
4	Packing	PTFE or Graphite	PTFE or Graphite	PTFE or Graphite	PTFE or Graphite
5	Retaining Ring	316 SS / 316 SS Nace	316L SS / 316L SS Nace	316 SS / 316 SS Nace	Exotic
6	Stem	316 SS / 316 SS Nace	316L SS / 316L SS Nace	316 SS / 316 SS Nace	Exotic
7	Tip	316 SS / 316 SS Nace	316L SS / 316L SS Nace	316 SS / 316 SS Nace	Exotic
8	Locknut	303 SS	303 SS	303 SS	303 SS
9	Handle	303 SS	303 SS	303 SS	303 SS
10	Yoke (Note 3)	316 SS	316 SS	316 SS	316 SS
11	Yoke Ring (Note 3)	316 SS	316 SS	316 SS	316 SS

Notes:

- 1 - Carbon steel valve bodies and components are zinc plated
- 2 - See product designator (next page) for full list of materials
- 3 - HK11, HK21, HK31, & HK41 Only

**HK 11, 21, or 31
(HK31 Shown)**

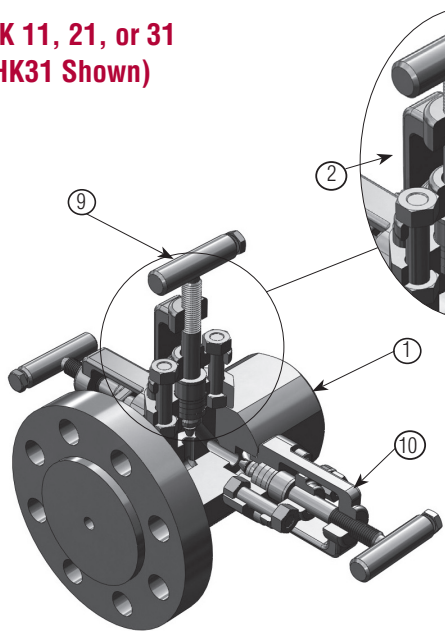

**HK 10, 20, or 30
(HK30 Shown)**

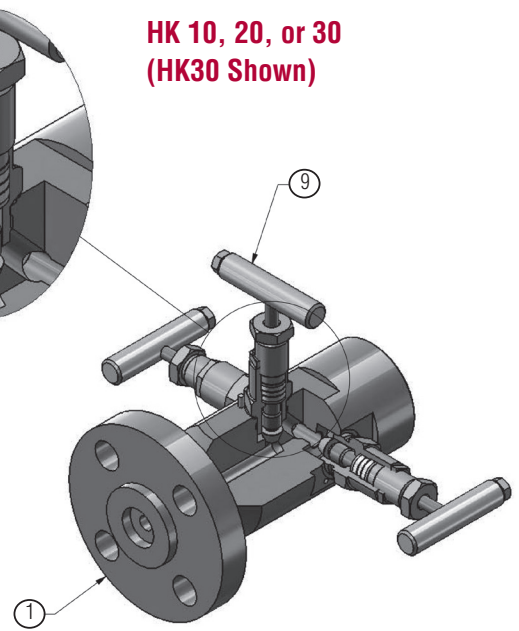



MODEL	BODY CONFIG.	BODY MAT'L	INLET SIZE	INLET TYPE	OUTLET SIZE	OUTLET TYPE	STEM/TIP	SEAT MAT'L	PACKING	OPTION	OPTION
HK10	2	2	3	C	3	1	4	1	3	A	8

MODEL	TYPE
HK10	Single Block Screwed Bonnet
HK11	Single Block OS&Y Bonnet
HK20	Single Block & Bleed Screwed Bonnet
HK21	Single Block & Bleed OS&Y Bonnet
HK30	*Double Block & Bleed Screwed Bonnet
HK31	*Double Block & Bleed OS&Y Bonnet
HK40	**Double Block & Bleed Screwed Bonnet
HK41	**Double Block & Bleed OS&Y Bonnet

* Block > Bleed > Block ** Block > Block > Bleed

BODY CONFIGURATION	
1	Hard Seat Block Valve(s)
2	Soft Seat Block Valve(s)
3	Hard Seat Primary and Vent Valve and Soft Seat Secondary Block Valve (HK30 and HK31 only)
0	10,000 PSI Hard Seat Primary & Secondary Block Valves, with Hard Seat Vent Valve *For HK10, HK20, HK30 only

2 & 3 - soft seat is limited to 200°F and 1500 psi (103°C and 93 bar)
Vent valve always hard seat

BODY MATERIAL	
U	316SS (forged)
D	316SS NACE (forged)
Y	A182F 316L (forged)
3	A182F 316L NACE (forged)
P	Carbon Steel A105
N	Carbon Steel, A105 NACE
6	Duplex A182 F51 (forged)
4	Super Duplex A182 F55 (forged)
H	Hastelloy C
X	Alloy 20
K	Low Temp CS A350 LF2 (forged)
7	Inconel 625
I	Incoloy 825
M	Monel 400 (forged)

INLET SIZE	
1	1/4" (DN8)
2	3/8" (DN10)
3	1/2" (DN15)
4	3/4" (DN20)
5	1" (DN25)
6	1-1/2" (DN40)
7	2" (DN50)

INLET TYPE	
1	MNPT
3	FNPT
4	FSW
C	150# RF
D	300# RF
G	600# RF
H	900/1500# RF
K	2500# RF
L	150# RTJ
M	300# RTJ
N	600# RTJ
P	900/1500# RTJ
R	2500# RTJ

OUTLET SIZE	
1	1/4"
2	3/8"
3	1/2" (DN15)
4	3/4" (DN20)
5	1" (DN25)
6	1-1/2" (DN40)
7	2" (DN50)
9	Flanged - Same as inlet

OUTLET TYPE	
1	FNPT
7	MNPT
2	FSW
9	Flanged - Same as inlet

BALL & STEM / NRT (VENT VALVE)	
4	316/316 Stem w/ NRT tip
3	316/316 NACE Stem w/ NRT tip
5	316/Stellite Stem w/ NRT tip
K	316/Monel Stem w/ NRT tip
Y	316L/316L Stem w/ NRT tip
A	316L/316L NACE Stem w/ NRT tip
M	Duplex/Duplex Stem w/ NRT tip
C	Super Duplex/Super Duplex Stem w/ NRT tip
D	Hastelloy C/Hastelloy C Stem w/ NRT tip
G	Alloy 20/Alloy 20 Stem w/ NRT tip
6	I-625/I-625 Stem w/ NRT tip
7	I-825/I-825 Stem w/ NRT tip
B	Monel/Monel Stem w/ NRT tip

Note: For different NRT tip material, contact factory

SEAT MATERIAL	
1	Integral Seat
4	* C-PEEK (Body configuration "2" and "3" only)

* Contact factory for other seat materials

PACKING	
2	Teflon Packing
3	Graphite Packing (fire safe selection)

OPTION*	
M	Two Outlets
N	Three Outlets
S	Swivel Adapter**
C	Plugged vent option (same material as body)
D	1/4" Vent Port
F	3/4" Vent Port
6	100% 316 non-wet parts
8	Tamper Proof/Lockout Handle - Block Valve(s)
9	Tamper Proof/Lockout Handle - Vent Valve
G	Bonnet Grease Fitting

*Note: Choose any two options in alpha-numerical order

** Consult factory for swivel adapter ordering options



API 6A Flanged Hexbloks - Ball and Needle

- Flange sizes of 1-13/16", 2-1/16", and 2-9/16"
- Flange types 2,000, 3,000, 5,000, and 10,000 API.
- API 607 6th addition fire safe.
- Heavy duty hex valve non-rotating tip designed needle valve.
- 10mm and 15mm bore sizes are available.
- Single or double flange configurations are available.
- Large variety of materials are available (Stainless Steel, Duplex, Super-Duplex, Inconel, etc.)

HK32

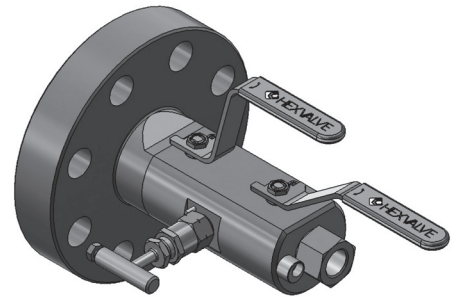

HK30

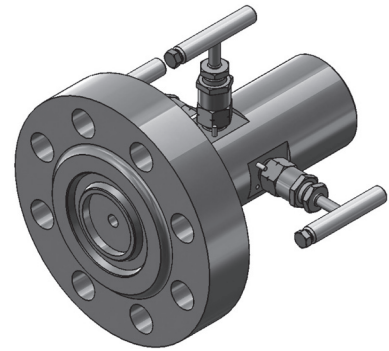

Dimensions (API 1-13/16" 10,000 PSI Flange x 1/2" FNPT Shown)

HK32
Weight = 28lbs

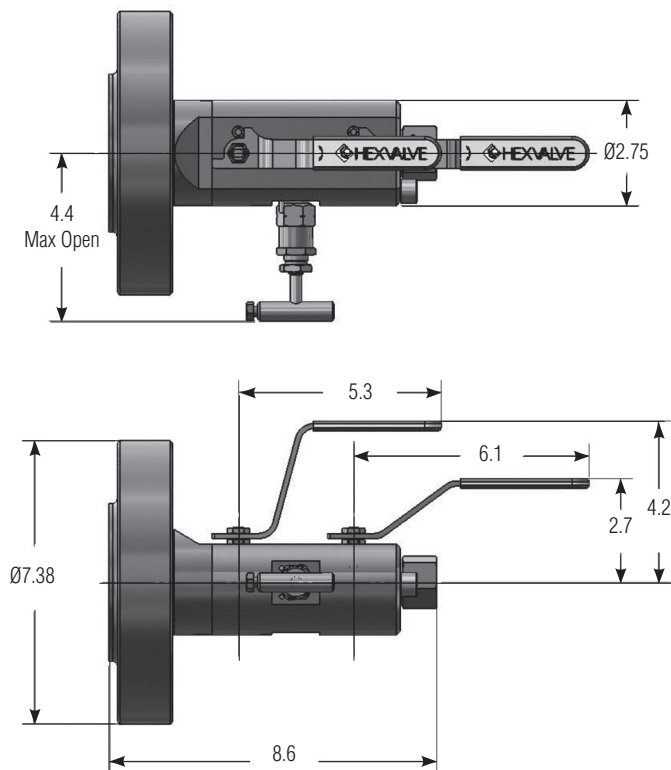

HK30
Weight = 30lbs

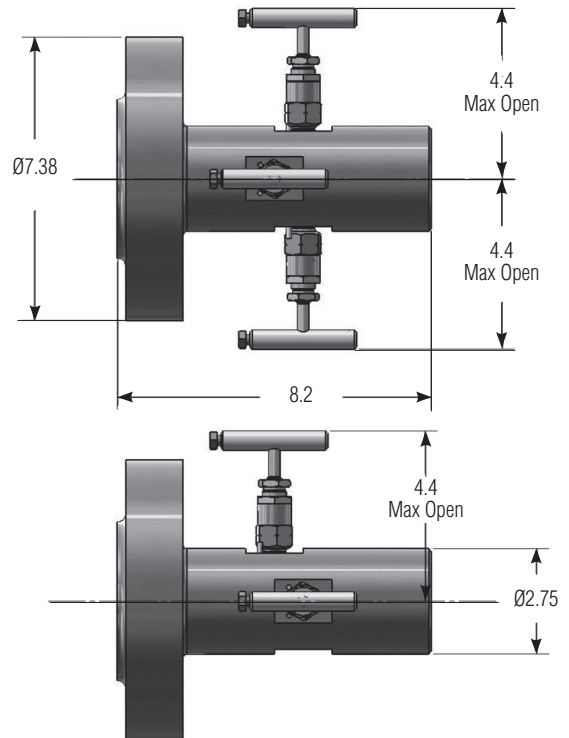



MODEL	BODY CONFIG.	BODY MAT'L	INLET SIZE	INLET TYPE	OUTLET SIZE	OUTLET TYPE	BALL & STEM/TIP	BALL SEAT MAT'L	PACKING	OPTION	OPTION
HK22	0	U	N	A	D	S	4	3	2	M	D

MODEL	TYPE
HK10	Single Block Screwed Bonnet
HK12	Single Block Ball
HK20	Single Block & Bleed Screwed Bonnet
HK22	Single Block Ball & Bleed (vent)
HK30	* Double Block & Bleed Screwed Bonnet
HK32	* Double Block Ball & Bleed (vent)
HK42	** Double Block Ball & Bleed (vent)

* Block > Bleed > Block configuration

** Block > Block > Bleed configuration

BODY CONFIGURATION	
A	10mm 2,000 PSI Soft Seat Primary & Secondary Block Valves, with Hard Seat Vent Valve
B	10mm 3,000 PSI Soft Seat Primary & Secondary Block Valves, with Hard Seat Vent Valve
C	10mm 5,000 PSI Soft Seat Primary & Secondary Block Valves, with Hard Seat Vent Valve
0	10,000 PSI Hard Seat Primary & Secondary Block Valves, with Hard Seat Vent Valve *For HK10, HK20, HK30 only

BODY MATERIAL	
U	316SS (forged)
D	316SS NACE (forged)
Y	A182F 316L (forged)
3	A182F 316L NACE (forged)
P	Carbon Steel A105
N	Carbon Steel, A105 NACE
6	Duplex A182 F51 (forged)
4	Super Duplex A182 F55 (forged)
H	Hastelloy C
X	Alloy 20
K	Low Temp CS A350 LF2 (forged)
7	Inconel 625
I	Incoloy 825
M	Monel 400 (forged)

INLET SIZE	
C	5/16"
3	1/2"
D	9/16"
4	3/4"
N	1-13/16"
O	2-1/16"
P	2-9/16"

INLET TYPE	
A	API 6A - Ring Groove
S	Medium Pressure Cone & Thread Fitting
T	High Pressure Cone & Thread Fitting
1	MNPT
3	FNPT
4	FSW

OUTLET SIZE	
C	5/16"
3	1/2"
D	9/16"
4	3/4"
N	1-13/16"
O	2-1/16"
P	2-9/16"

OUTLET TYPE	
A	API 6A - BX Ring Groove
S	Medium Pressure Cone & Thread Fitting
T	High Pressure Cone & Thread Fitting
1	MNPT
3	FNPT
4	FSW

BALL & STEM / NRT (VENT VALVE)	
4	316/316 Stem w/ NRT tip
3	316/316 NACE Stem w/ NRT tip
5	316/Stellite Stem w/ NRT tip
K	316/Monel Stem w/ NRT tip
Y	316L/316L Stem w/ NRT tip
A	316L/316L NACE Stem w/ NRT tip
M	Duplex/Duplex Stem w/ NRT tip
C	Super Duplex/Super Duplex Stem w/ NRT tip
D	Hastelloy C/Hastelloy C Stem w/ NRT tip
G	Alloy 20/Alloy 20 Stem w/ NRT tip
6	I-625/I-625 Stem w/ NRT tip
7	I-825/I-825 Stem w/ NRT tip
B	Monel/Monel Stem w/ NRT tip

Note: For different NRT tip material, contact factory

BALL SEAT MATERIAL	
3	PEEK (standard)

Contact factory for other seat materials

PACKING	
2	Teflon Packing
3	Graphite Packing (fire safe selection)

OPTION*	
M	Two Outlets
N	Three Outlets
6	100% 316 non-wet parts
S	Swivel Adapter**
C	Plugged vent option (same material as body)
V	OS&Y Bonnet - Vent Valve
D	1/4" Vent Port
F	3/4" Vent Port
9	Tamper Proof/Lockout Handle - Vent Valve

*Note: Choose any two options in alpha-numerical order

**Consult factory for swivel adapter ordering options



HEXVALVE

Hexblok Valves

ANSI 150# up to 2500# Class and API 10K
RF or RTJ Flanges & Threaded Ends
OS&Y and Screwed Bonnet Needle Valve



HEXVALVE

A Division of Richards Industries
3170 Wasson Road
Cincinnati, OH 45209

Toll Free. 800.543.7311
Local. 513.533.5600
Fax. 513.871.0105

www.hexvalve.com