



LOWFLOW

a division of Jordan Valve

JRH Series

Gas Pressure Reducing Valves

GAS PRESSURE REDUCING VALVES

The LowFlow JRH Series of high pressure regulators has the ability to handle high pressures as well as low flows. These valves are typically used in research and sampling systems for general, corrosive and specialty gas and liquid service. Typical applications include gas chromatography and flame ionization detectors, as well as other industrial controls.

Features:

- Top entry design facilitates in-line cleaning and maintenance
- Barstock construction guarantees material integrity and surface finish
- High flow rate coupled with high rangeability reduces need for reduced trim sizes
- Optimized internal volume
- Proprietary Jorlon diaphragm material provides exceptionally long life
- Kel-F soft seat material for ANSI Class VI shutoff



JRH SERIES FLOW CONFIGURATIONS

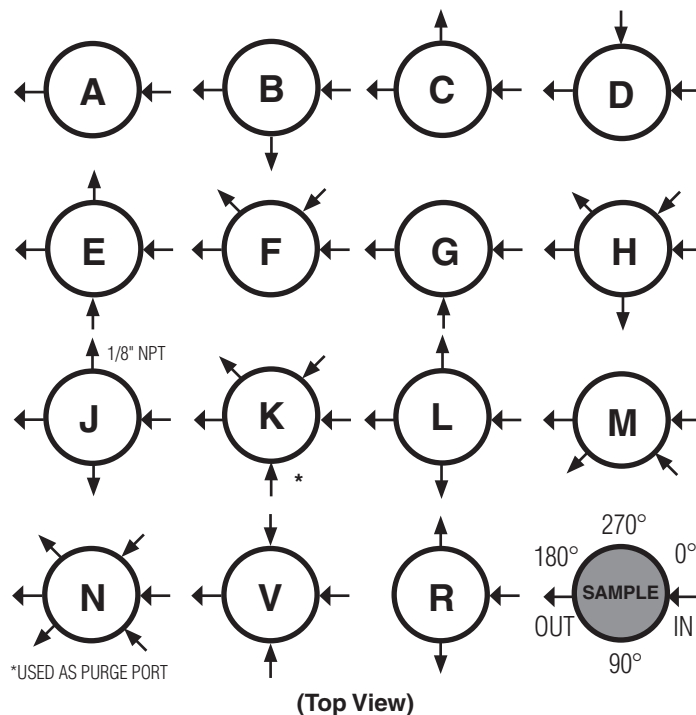

A Division of
Jordan Valve
3170 Wasson Road
Cincinnati, OH 45209

toll free. 800.543.7311
local. 513.533.5600
fax. 513.871.0105

www.lowflowvalve.com

JRH SERIES SPECIFICATIONS

Line Size: 3/8" & 1/2" (DN10 & DN15)

End Connections

- Threaded
- Socket Weld
- Flanged

Soft Seat Materials for ANSI Class VI Shut-off

- KEL-F with Viton O-ring to +250°F (+120°C)

Body Material

- 316L SST – Standard
- Contact factory for other body/trim/seat materials

Diaphragm Material: Jorlon

Maximum Inlet Pressure: 4000 psig (276 bar) @ -20°F (-28,9°C)

Pressure at Maximum Temperature: 2165 psi @ 350°F (149 bar @ 177°C) with KEL-F seat

Maximum Pressure Drop: 3000 psi (207 bar)

Spring Ranges

- 2 – 10 psi (0,14 – 0,69 bar)
- 5 – 20 psi (0,34 – 1,4 bar)
- 15 – 100 psi (1,0 – 6,9 bar)
- 50 – 175 psi (3,5 – 12,1 bar)
- 75 – 450 psi (5,2 – 31 bar)

Flow Characteristics

- Cv 0.8

Options

- Panel Mounting
- Captured Vent
- Self Relieving
- Locking Wire
- Tamper Proof
- Lockout Device

OPTIONS & DEFINITIONS

Panel Mount The panel mount feature utilizes a threaded spring housing and a panel mount ring to secure the regulator to an instrument panel. This option requires a 1-1/2" panel cut out.

Captured Vent The captured vent design provides maximum safety for the user when handling toxic or hazardous media. It features a 1/8" FNPT port located on the spring housing. The user can easily tube this vent to a safe location. This option can be incorporated into a self-relieving regulator that provides an additional port to permit the safe expulsion of hazardous media.

Self Relieving The self relieving option is used for internal venting of downstream pressure. From a practical standpoint, it allows for immediate reduction in pressure setpoints and automatically alleviates regulator lock up.

Locking Wire The locking wire option utilizes a lead sealed metal wire to physically hold the adjusting screw in place to prevent any unwanted set point changes.

Tamper Proof The tamper proof option replaces the standard adjusting knob with a stainless steel acorn nut.

Lockout Device The lockout device is a 2 piece polypropylene enclosure which encapsulates the adjustment knob and prevents unwanted set point changes. The part number required for this valve is 26970. (Lock not included)

JRH SERIES FEATURES & BENEFITS

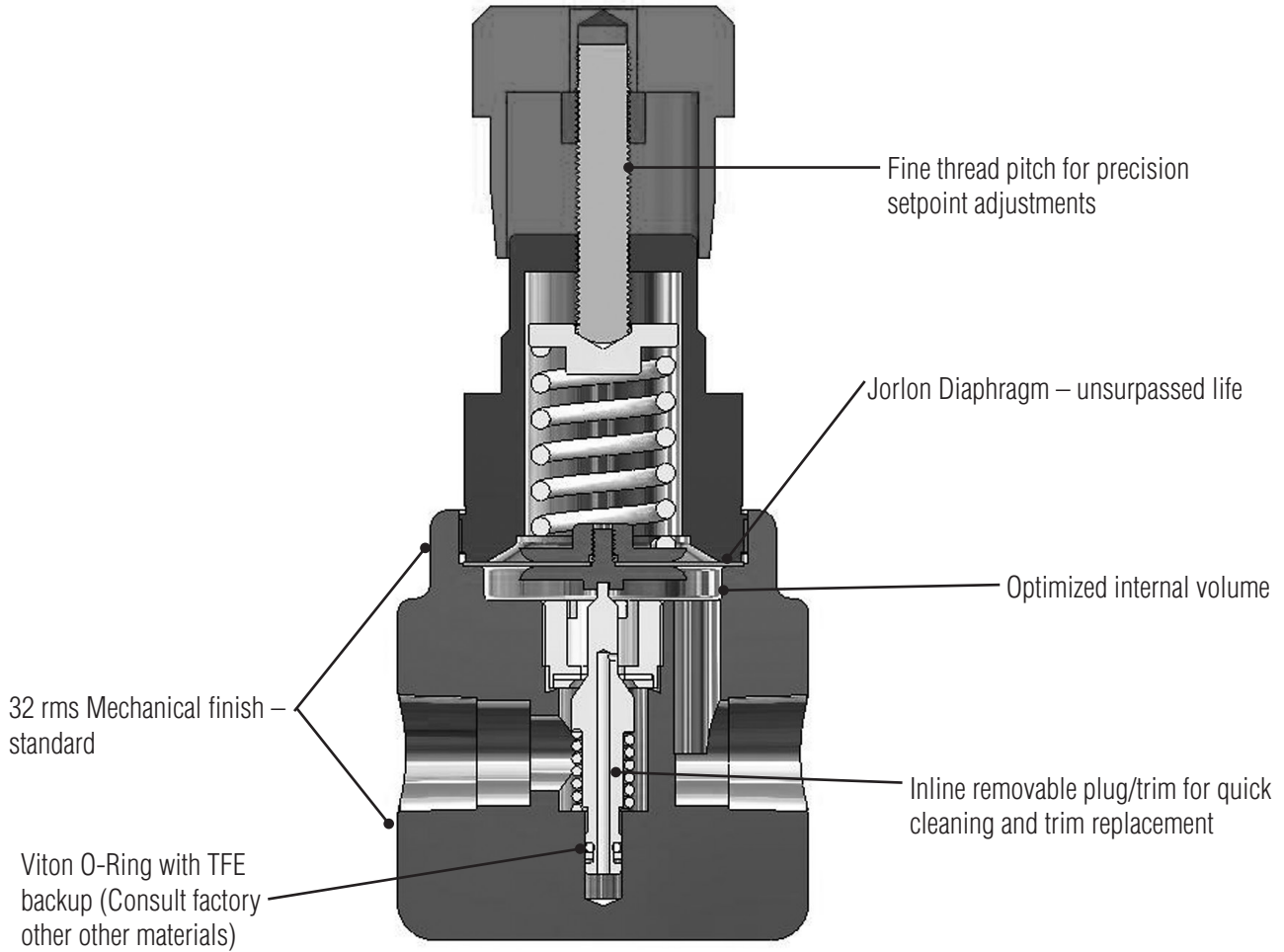

JRH SERIES DIMENSIONS

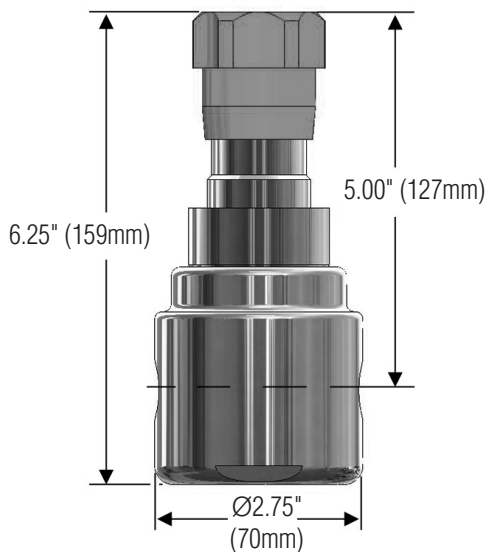

Weight 4.8 Lbs (2,2 Kgs)

SIZING

All of the following sizing charts for the JRH were derived using Nitrogen as the flow medium at ambient conditions. In order to convert your gas to the equivalent volume of Nitrogen, multiply your application's flow by the appropriate multiplying factor.

GAS	Specific Gravity	Multiplying Factor
Air	1	1.02
Ammonia	0.596	0.79
Argon	1.379	1.19
Arsine	2.695	1.67
CO	0.967	1
CO2	1.529	1.26
Ethylene	0.975	1

GAS	Specific Gravity	Multiplying Factor
Helium	0.138	0.38
Hydrogen	0.07	0.27
Methane	0.555	0.76
Natural Gas	0.555	0.76
Nitrogen	0.967	1
Oxygen	1.105	1.07
Propane	0.495	0.72

For all other gaseous media, use the following formula to calculate the appropriate multiplying factor.

(Sg = Specific Gravity of the media)

$$\frac{1}{\sqrt{\frac{0.967}{Sg(\text{any gas})}}}$$

CV TRIM SELECTION INSTRUCTIONS

1. Select a graph on the following 8 pages that best represents your outlet pressure set point and flow range.
2. Select the inlet pressure line on the graph (horizontal sloped line, P1) that reflects your application's actual inlet pressure.
3. That line indicates the Pressure/Flow capabilities of the Cv trim under flowing conditions

FLOW DATA FOR CV TRIM SELECTION

The graphs illustrate the change or "droop" in outlet pressures as the flow rate increases, and the lockup (setpoint rise) as flow decreases and approaches zero.

Maximum inlet pressure: 4000 psig (276 bar)

Flow Coefficient: 0.8

Range Spring: 2 – 10 psi (0,14 – 0,69 bar)

Set Point: 5 psig

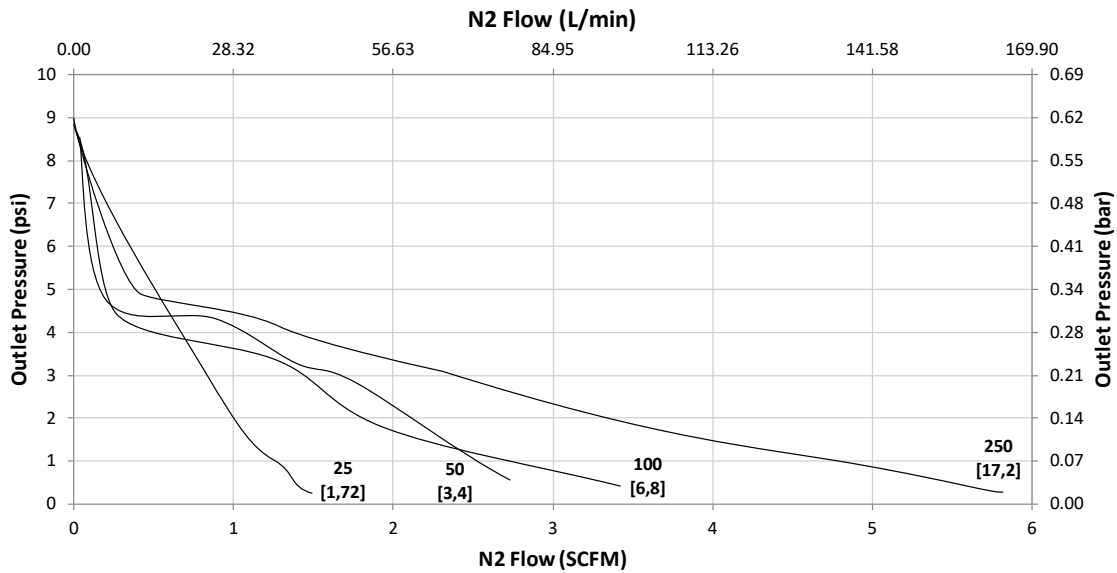

Flow Coefficient: 0.8

Range Spring: 2 – 10 psi (0,14 – 0,69 bar)

Set Point: 10 psig

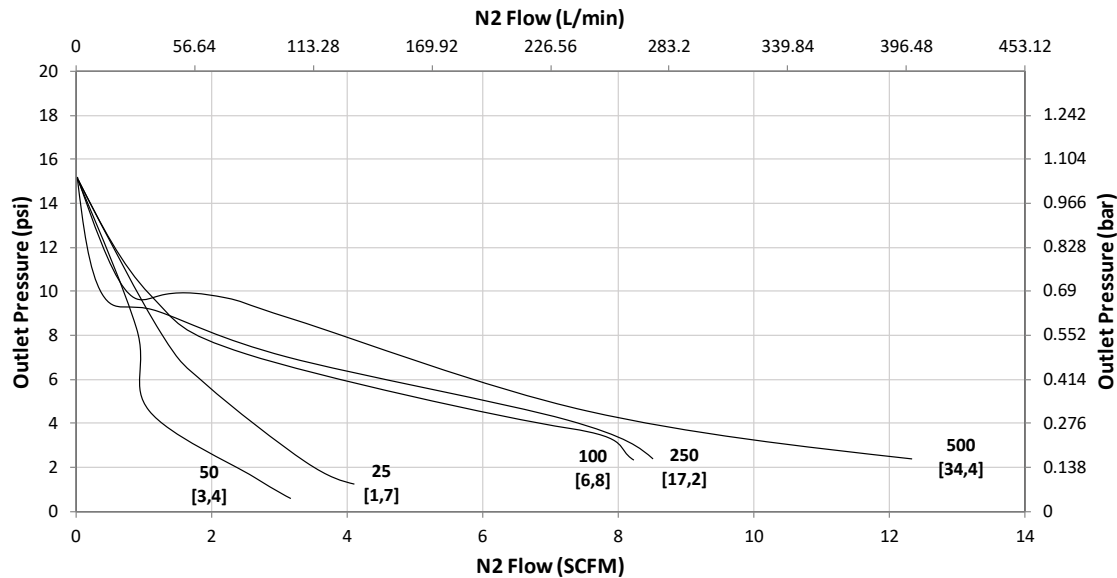

FLOW DATA FOR CV TRIM SELECTION

The graphs illustrate the change or "droop" in outlet pressures as the flow rate increases, and the lockup (setpoint rise) as flow decreases and approaches zero.

Maximum inlet pressure: 4000 psig (276 bar)

Flow Coefficient: 0.8

Range Spring: 5 – 20 psi (0,34 – 1,4 bar)

Set Point: 5 psig

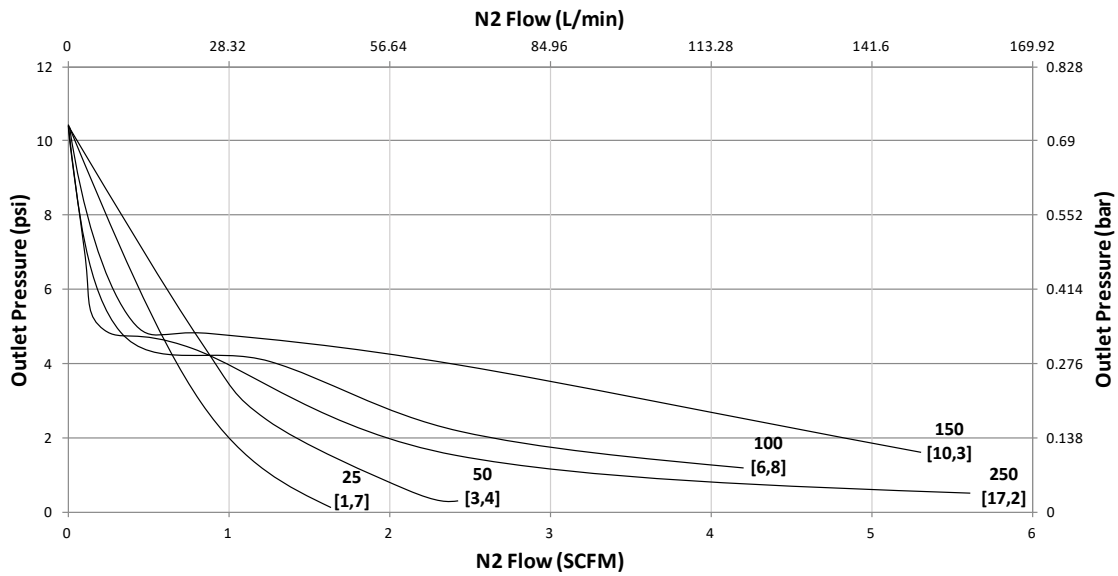

Flow Coefficient: 0.8

Range Spring: 5 – 20 psi (0,34 – 1,4 bar)

Set Point: 10 psig

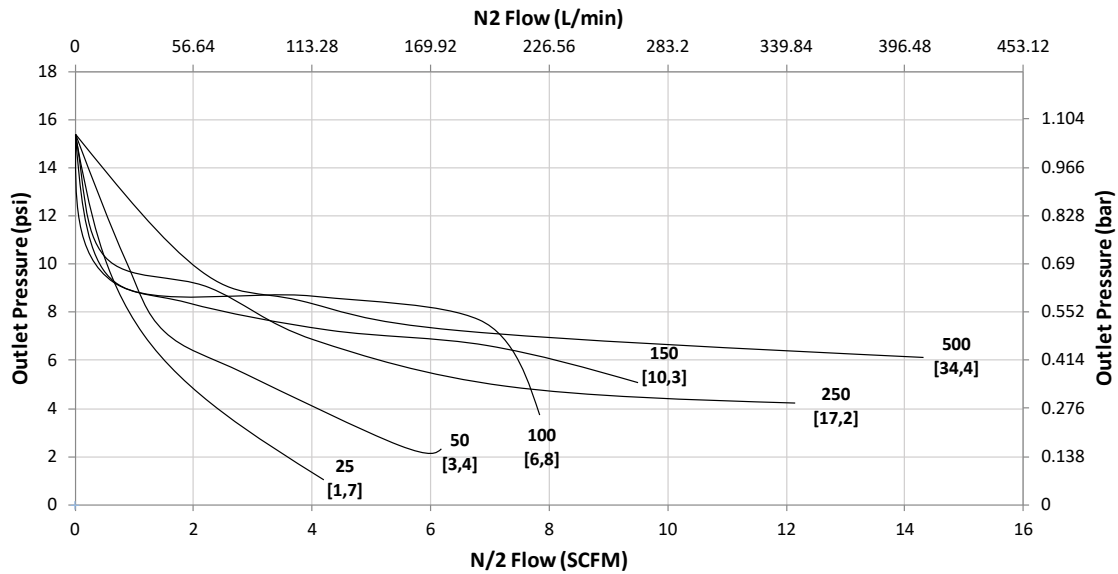

FLOW DATA FOR CV TRIM SELECTION

The graphs illustrate the change or "droop" in outlet pressures as the flow rate increases, and the lockup (setpoint rise) as flow decreases and approaches zero.

Maximum inlet pressure: 4000 psig (276 bar)

Flow Coefficient: 0.8

Range Spring: 5 – 20 psi (0,34 – 1,4 bar)

Set Point: 20 psig

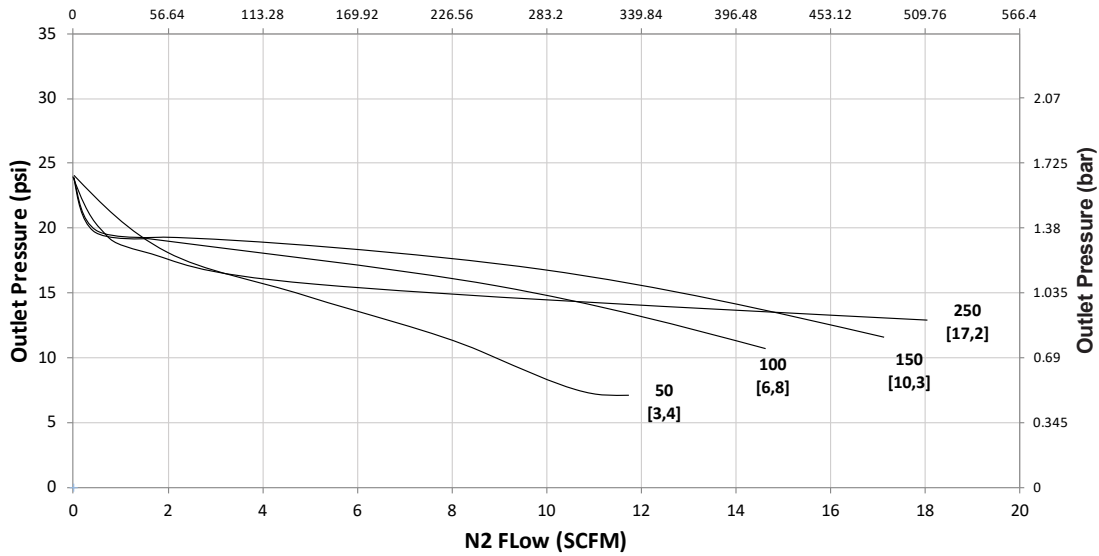

Flow Coefficient: 0.8

Range Spring: 15 – 100 psi (1,0 – 6,9 bar)

Set Point: 15 psig / 30 psig

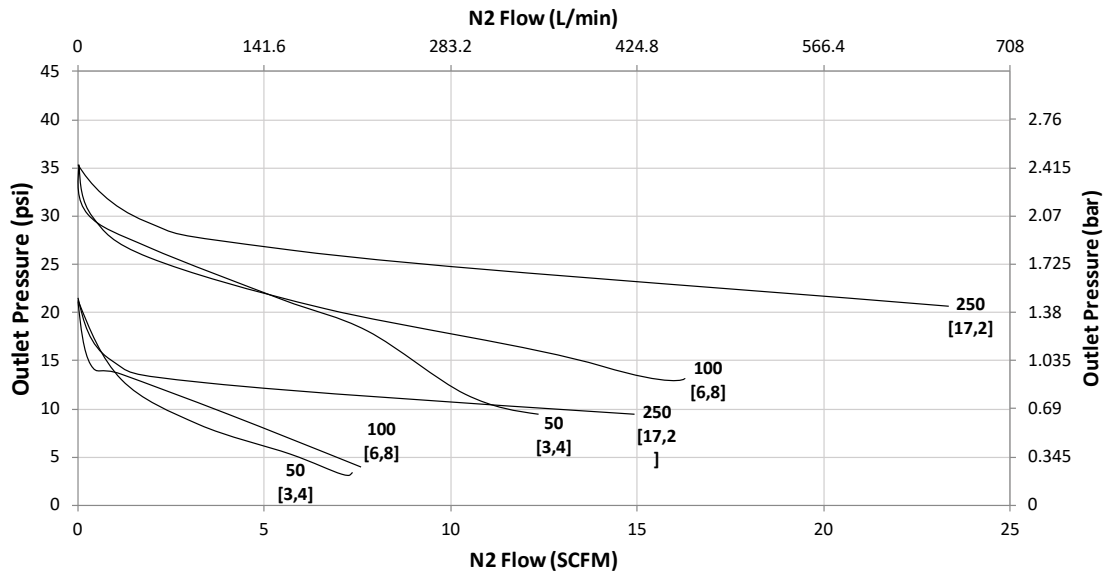

FLOW DATA FOR CV TRIM SELECTION

The graphs illustrate the change or "droop" in outlet pressures as the flow rate increases, and the lockup (setpoint rise) as flow decreases and approaches zero.

Maximum inlet pressure: 4000 psig (276 bar)

Flow Coefficient: 0.8

Range Spring: 15 – 100 psi (1,0 – 6,9 bar)

Set Point: 15 psig / 30 psig

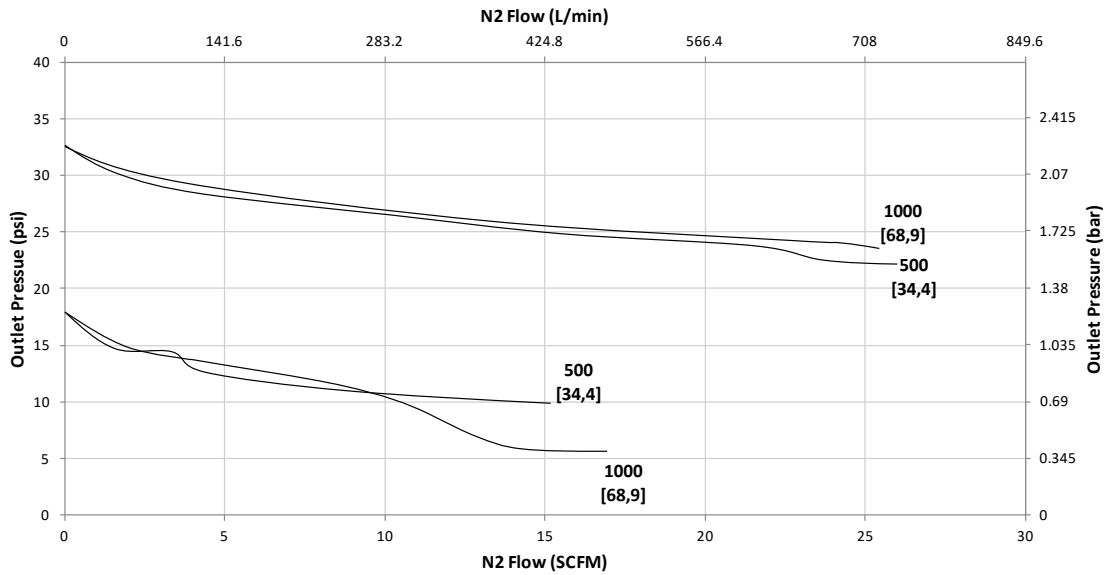

Flow Coefficient: 0.8

Range Spring: 15 – 100 psi (1,0 – 6,9 bar)

Set Point: 50 psig / 75 psig

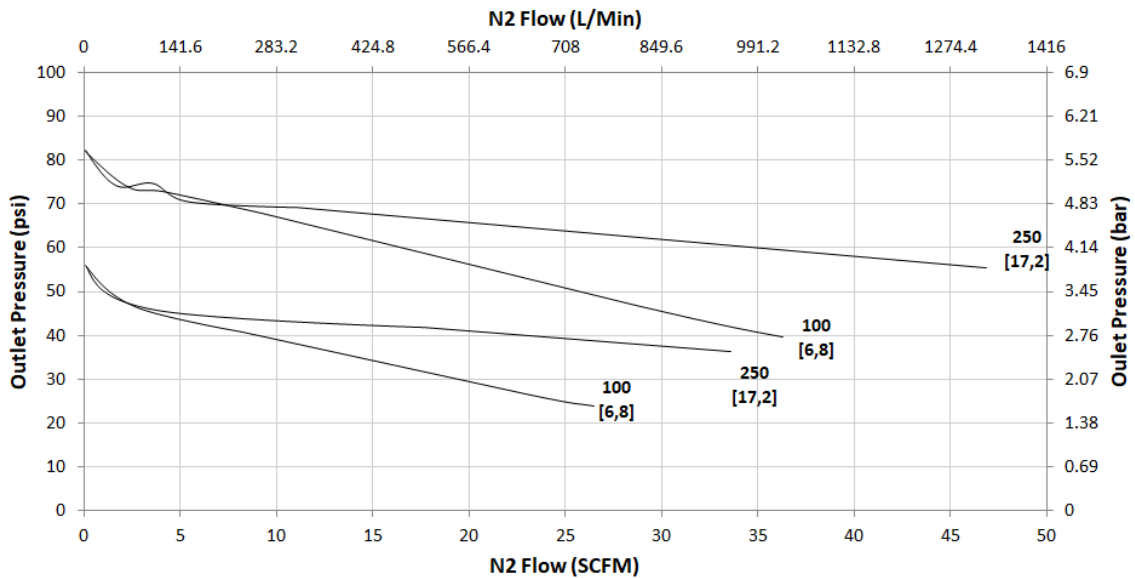

FLOW DATA FOR CV TRIM SELECTION

The graphs illustrate the change or "droop" in outlet pressures as the flow rate increases, and the lockup (setpoint rise) as flow decreases and approaches zero.

Maximum inlet pressure: 4000 psig (276 bar)

Flow Coefficient: 0.8

Range Spring: 15 – 100 psi (1,0 – 6,9 bar)

Set Point: 50 psig / 75 psig

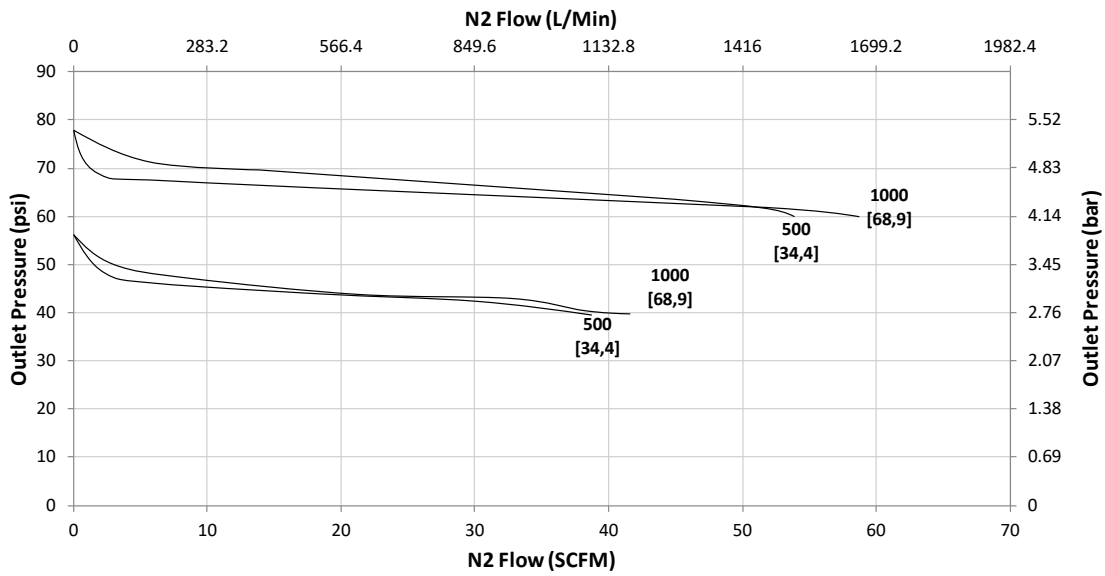

Flow Coefficient: 0.8

Range Spring: 15 – 100 psi (1,0 – 6,9 bar)

Set Point: 100 psig

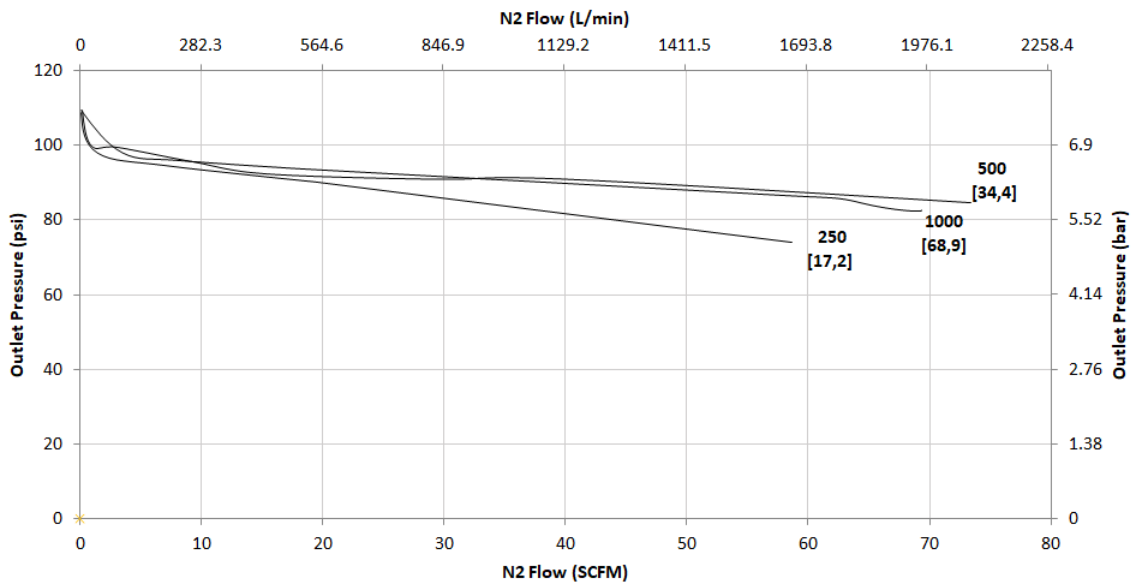

FLOW DATA FOR CV TRIM SELECTION

The graphs illustrate the change or "droop" in outlet pressures as the flow rate increases, and the lockup (setpoint rise) as flow decreases and approaches zero.

Maximum inlet pressure: 4000 psig (276 bar)

Flow Coefficient: 0.8

Range Spring: 50 – 175 psi (3,5 – 12,1 bar)

Set Point: 50 psig

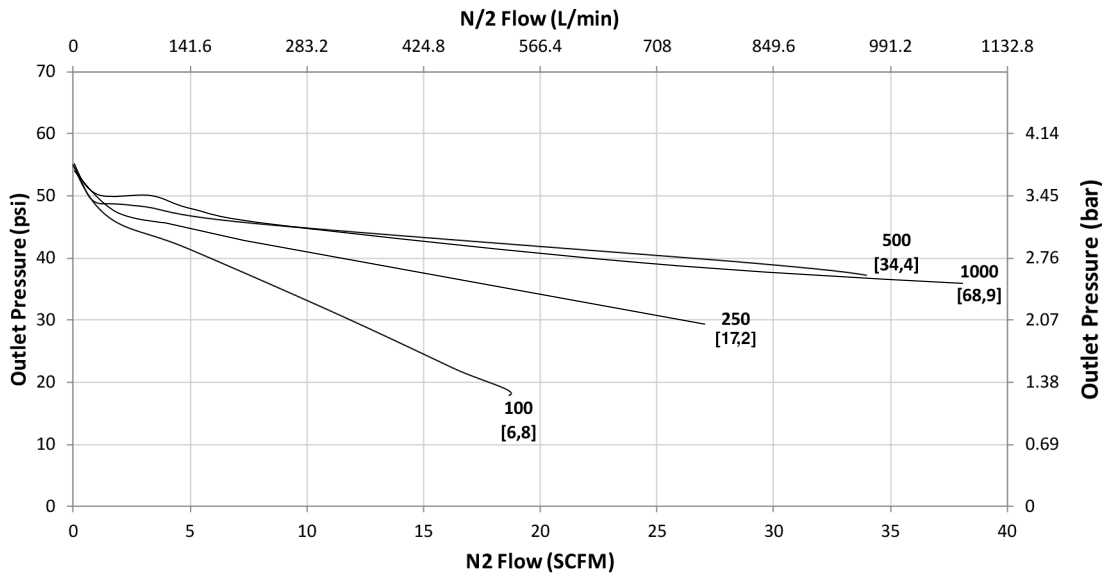

Flow Coefficient: 0.8

Range Spring: 50 – 175 psi (3,5 – 12,1 bar)

Set Point: 100 psig

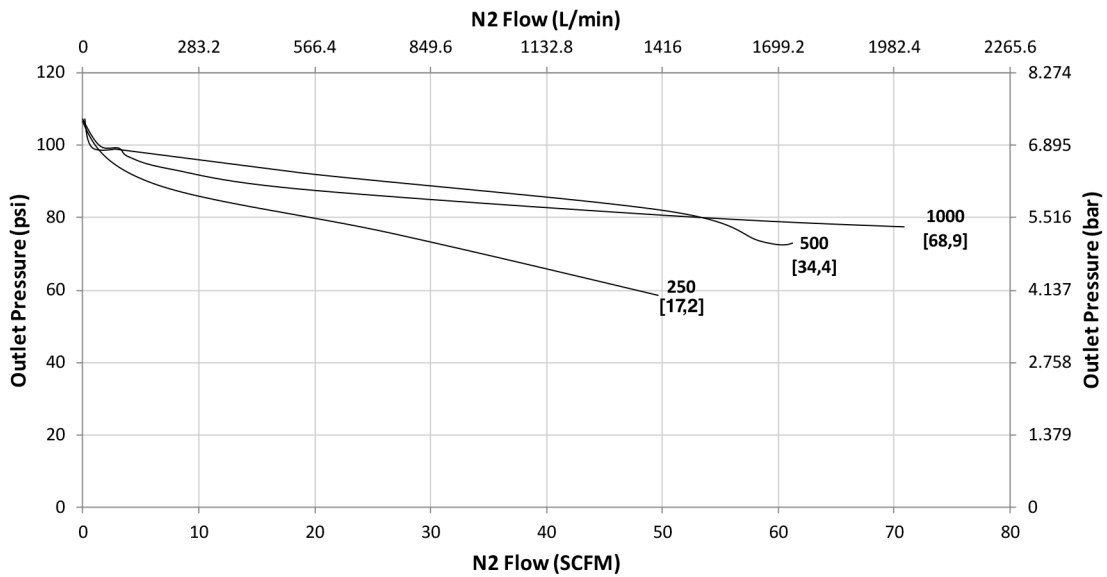

FLOW DATA FOR CV TRIM SELECTION

The graphs illustrate the change or "droop" in outlet pressures as the flow rate increases, and the lockup (setpoint rise) as flow decreases and approaches zero.

Maximum inlet pressure: 4000 psig (276 bar)

Flow Coefficient: 0.8

Range Spring: 50 – 175 psi (3,5 – 12,1 bar)

Set Point: 150 psig / 175 psig

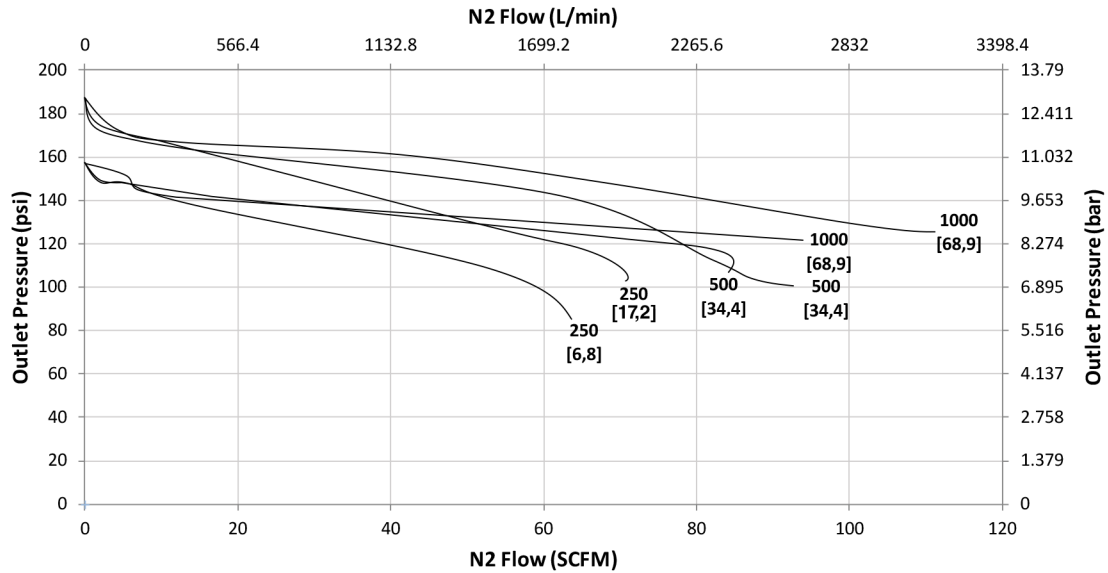

Flow Coefficient: 0.8

Range Spring: 75 – 450 psi (5,2 – 31 bar)

Set Point: 75 psig / 100 psig

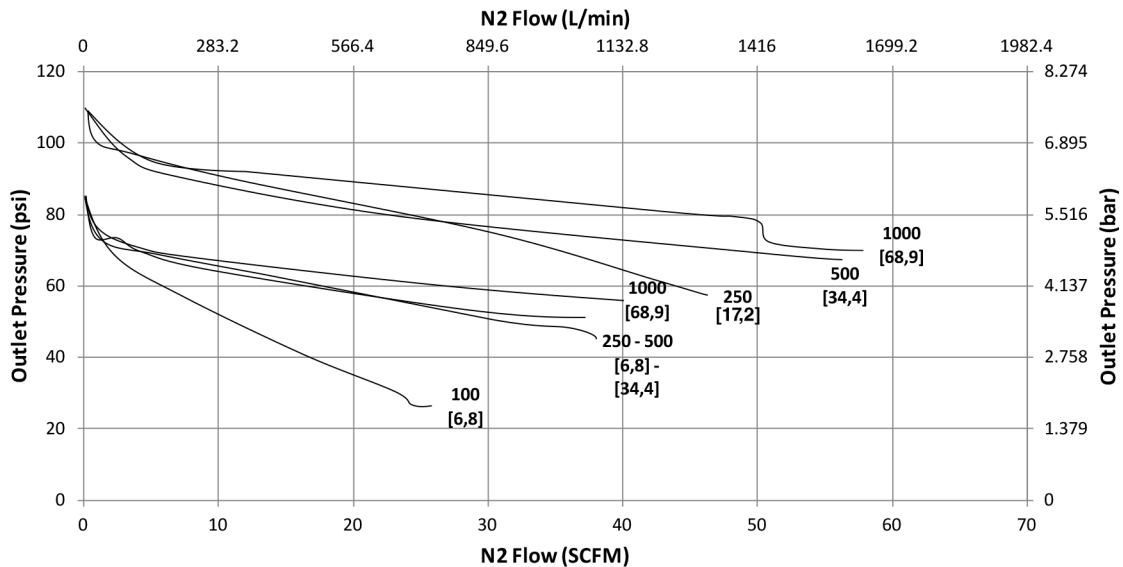

FLOW DATA FOR CV TRIM SELECTION

The graphs illustrate the change or "droop" in outlet pressures as the flow rate increases, and the lockup (setpoint rise) as flow decreases and approaches zero.

Maximum inlet pressure: 4000 psig (276 bar)

Flow Coefficient: 0.8

Range Spring: 75 – 450 psi (5,2 – 31 bar)

Set Point: 200 psig

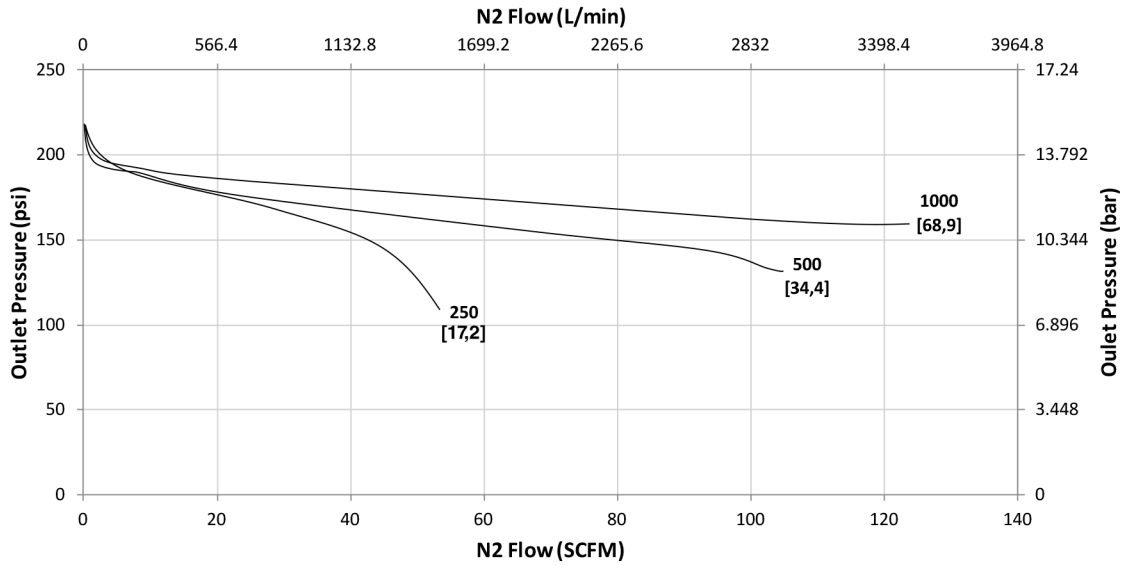

Flow Coefficient: 0.8

Range Spring: 75 – 450 psi (5,2 – 31 bar)

Set Point: 300 psig / 400 psig / 450 psig

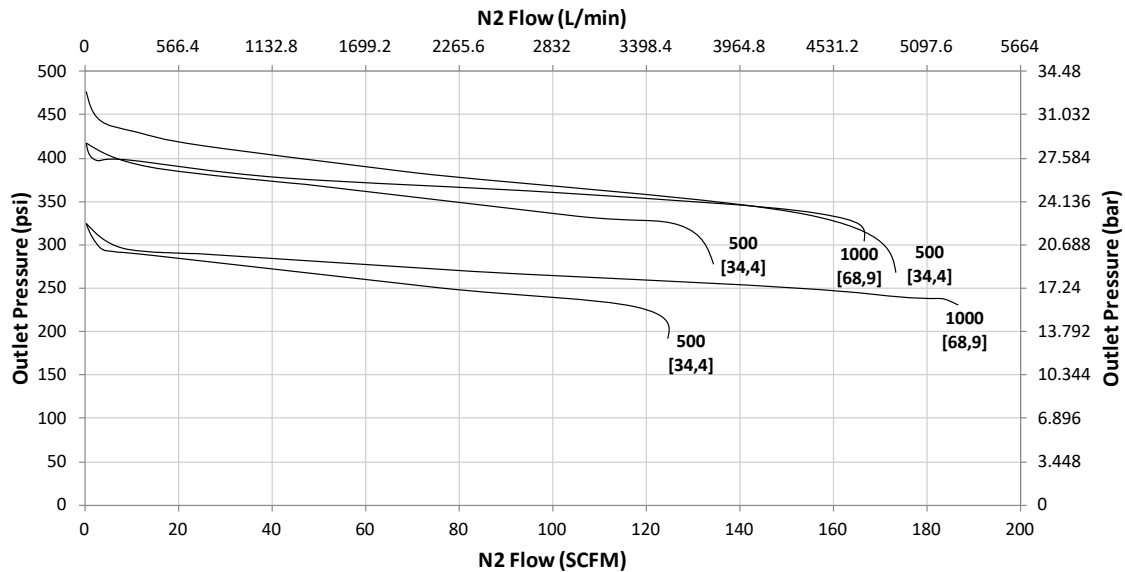

JRH SERIES ORDERING SCHEMATIC

Model	Size	Material	1 & 2	3 & 4	5 & 6	7 & 8	9 & 10	11 & 12	13 & 14	15	16	17
—	—	—	—	—	—	—	—	—	—	—	—	—

Model	
JRH	Pressure Reducing Valve

Size	
038	3/8"
050	1/2"

Material	
6L	Stainless Steel 316L

1 & 2		Body Feature	
End Connection		Port Configuration	
B	FNPT 3/8"	A	Port "A"
C	FNPT 1/2"	B	Port "B"
		C	Port "C"
		D	Port "D"
		E	Port "E"
		F	Port "F"
		G	Port "G"
		H	Port "H"
		J	Port "J"
		K	Port "K"
		L	Port "L"
		M	Port "M"
		N	Port "N"
		V	Port "V"
		R	Port "R"
ZZ	Non-Standard		

3 & 4		Trim
4S		Cv 0.8
4R		Cv 0.8 Self-Relieving
ZZ		Non-Standard

5 & 6		Seat Material
K4		KEL-F/Viton CV 0.8

7 & 8		Range Spring/Outlet Pressure
E1		2- 10 psi
E2		5 - 20 psi
E3		15 - 100 psi
E4		50 - 175 psi
E5		75 - 450 psi

9 & 10		Diaphragm Material
JL		Jorlon
ZZ		Non-Standard

11 & 12		Actuator
		Ranges E1 thru E5
SK		Standard
CV		Captured Vent
PM		Panel Mount
TP		Tamper Proof
LW		Locking Wire
ZZ		Non-Standard

13 & 14		Inlet Gauge
AA		0 - 30 psig
BB		0 - 60 psig/bar (dual)
CC		0 - 100 psig/bar (dual)
DD		0 - 160 psig/bar (dual)
EE		0 - 200 psig/bar (dual)
FF		0 - 300 psig/bar (dual)
GG		0 - 400 psig/bar (dual)
HH		0 - 600 psig/bar (dual)
JJ		0 - 1000 psi/bar (dual)
KK		0 - 2000 psi/bar (dual)
LL		0 - 3000 psi/bar (dual)
MM		0 - 5000 psi/bar (dual)
NN		None
ZZ		Non-Standard

* Customer assumes all responsibility for possible damage or injury if selected gauge span does not fully cover range spring / outlet pressure option

JRH SERIES ORDERING SCHEMATIC

Model	Size	Material	1 & 2	3 & 4	5 & 6	7 & 8	9 & 10	11 & 12	13 & 14	15	16	17
	—	—	/									

15	Outlet Gauge
A	0 - 30 psig
B	0 - 60 psig/bar (dual)
C	0 - 100 psig/bar (dual)
D	0 - 160 psig/bar (dual)
E	0 - 200 psig/bar (dual)
F	0 - 300 psig/bar (dual)
G	0 - 400 psig/bar (dual)
H	0 - 600 psig/bar (dual)
J	0 - 1000 psi/bar (dual)
N	None
Z	Non-Standard

* Customer assumes all responsibility for possible damage or injury if selected gauge span does not fully cover range spring / outlet pressure option

16	SEP Compliance
0	None
G	SEP Compliant
Z	Non-Standard

17	Accessories
0	None
S	Clean for Oil Free*
X	Clean for Oxygen*
Z	Non-Standard

*Consult factory for compatible gauge options